

PRESS BRAKES

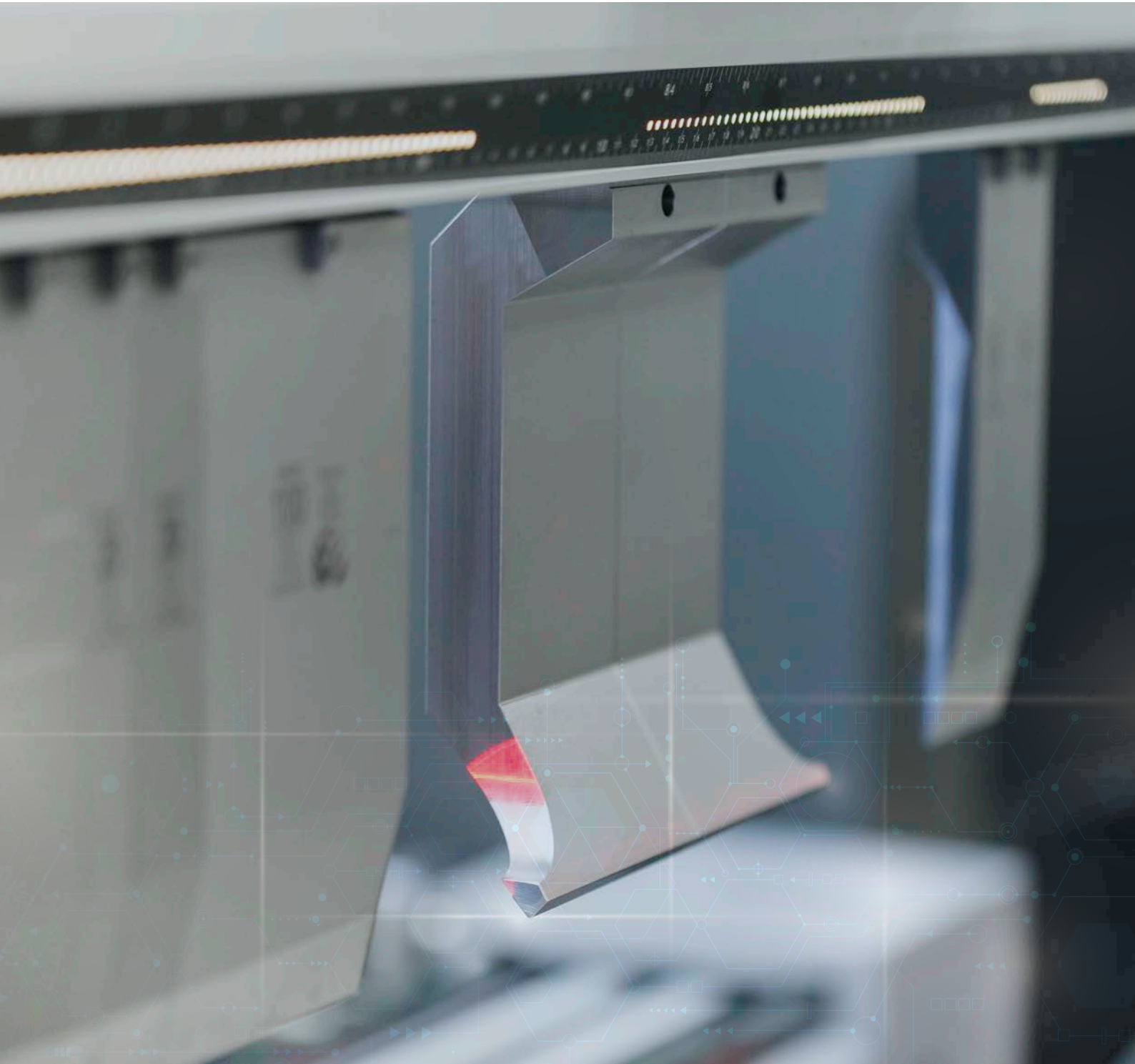

Press Brakes
SynchroMaster
EuroMaster-S
PressMaster

HACO's Affordable Bending Solutions to the Highest Standards

Always the right choice for your application

- SynchroMaster Series **4**
- EuroMaster-S Series **12**
- PressMaster Series **18**

Equipment

- FastBEND-2D/3D MT Premium **24**
- New Standard Tooling System **26**
- Smart Tool Locator **26**
- Sheet Following Systems **27**
- Lasersafe Optical Safety Guards **28**
- Angle Measuring System Alfa-F **30**
- Angle Measuring System IRIS Plus **31**
- Robot Bending **32**
- Tandem / Tridem Press Brakes **34**
- HDSY , Heavy Duty Press Brakes **35**

HACO's press brake series are the result of a decades long tradition in designing and manufacturing affordable **state-of-the art bending machines** for a wide variety of customers and applications.

HACO continues its policy of single source responsibility. Our in house developed **CNC controls** and **software solutions** have been recognized as being among the most user-friendly in the market. The new generation **Multi Touch** controls sets a new standard for an intuitive and user-friendly operator interface, introducing innovations such as **Smart Draft, Step Previewer** and **Combined Icons**.

HACO's attention for **design** and **manufacturing quality** has resulted in a worldwide reputation of long lasting production machines offering **excellent reliability** and **precision**.

FOLLOW THE HACO GROUP:
WWW.HACO.COM



TheHACOGroup



@haco_com



The HACO Group



hacogroup

Our Press Brakes Series



SynchroMaster (SRM)

Entry Level Machine

Entry level press brake with basic execution for operation with European Standard Tooling. Possibility to extend with straightforward options. Attractive price/quality ratio. Standard with user friendly 2D graphical touch control.



EuroMaster-S (EMS)

Standard Multifunctional Allround Machine

Multi level press brake with market oriented execution. Extensive choice of options, both basic and sophisticated. Innovative 2D Multi Touch graphical control. Excellent price-performance ratio. Integration of advanced safety equipment.



PressMaster (PM)

Top Level High-Spec Machine

Top level press brake with high-end specifications and execution. Increased Daylight Opening and Beam Stroke for increased bending freedom. Increased beam and backgauge speeds for high productivity. Innovative 3D Multi Touch graphical control. Possibility for extension with sophisticated options. Features accurate bending characteristics. Integration of advanced safety equipment.

SynchroMaster Series

Your entry-level machine

BEAM CONTROL

Beam parallelism and depth stop setting by means of bed referenced linear encoders for accurate beam position measurement, synchro module and proportional valve hydraulics

EASYBEND-2D T

Touch Screen control



EASYBEND-2D MT

Multi Touch Screen control (optional)



ROL1 CLAMP3 (optional)



ROL200 Manual or Pneumatic (optional)

SynchroMaster Series

SRM



*Model 40250
Flush Floor frame
design for all models*

CROWNING TABLE (OPTIONAL)

Compensates for ram and table deflection, ensuring consistent bending angles over the entire bending length.
Manual operation and CNC controlled versions (V-axis)

STANDARD BACKGAUGE X

Rigid backgauge for accurate sheet positioning



STANDARD EUROPEAN

Quick Manual Upper clamping
Manual bottom clamping



SynchroMaster Series

EasyBEND-2D T Control

EASYBEND-2D T CONTROL

- **18.5"** colour graphic LCD display with **Touch Screen Technology**
- WIN10 IoT operating system
- Multiple drawing methods
- Graphic simulation of work pieces with **Multitasking Real Time Solution Finding**
- **Automatic Bending Sequence Calculation** with collision control
- Automatic program generation
- Expandable up to **7 axes**:
 - standard Y1 + Y2
 - standard X-axis
 - optional R-axis
 - optional X-R-Z/Z' and X-R-Z1-Z2 axes
 - optional crowning (= V-axis)
- Material library up to **30 different materials**
- Tool library with graphical visualisation for
- **30 upper** and **30 lower tools**
- **Multi-language support**
- **USB Support** (stick included) + Network board
- **Remote diagnostics**
- **Programmable Beam Speed** and **Speed Change-Over Point**
- **Programmable Top Death Centre (TDC)**
- Programmable Backgauge Positioning with retraction



SynchroMaster Series

Standard Execution



EUROPEAN STANDARD (ES)

top tooling with Quick Manual Clamping arrangement

The European Standard Tooling System has proven its flexibility, affordability and precision during the last decades in an infinite number of sheet metal working shops. A wide choice of a vast number of top and bottom tools allows for an unpredictable number of applications in various materials and thicknesses.



X BACKGAUGE, expandable to X-R, X-R-Z/Z' and X-R-Z1-Z2

The SynchroMaster is standard equipped with a rigid and accurate X backgauge featuring average travelling speeds. Optional X-R (height programming), X-R-Z/Z' (symmetric finger programming) and X-R-Z1-Z2 (asymmetric finger programming) are available for increasing your range of applications.

Picture: X-R backgauge

- **EasyBEND-2D T control**
- **X Backgauge for accurate sheet positioning**
 - Stroke X = 800mm, maximum speed = 400mm/s
 - Stroke R = 250mm, maximum speed = 100mm/s (Optional)
- **European Standard (ES) top clamping with Quick Manual Clamping Arrangement**
- **Intermediate clamping with height 150mm (all models ≤ 3200 kN), height 120mm HD version (all models = 4000 kN)**

Your Competitive Edge

A. Excellent Value for Money

B. User Friendly EasyBEND-2D T graphical control

C. Proven Profitability for Various Workload Conditions

SynchroMaster Series

Technical Specifications

	Bending length	Capacity	Distance between housings	Gap	Daylight opening	Stroke	Table Height	Fast Approach Speed	Max. Bending Speed	Fast Return Speed	Motor Power	Length	Width	Height	Weight
	A	B	C	D	E	G						F	I	J	
MODEL	mm	kN	mm	mm	mm	mm	mm	mm/s	mm/s	mm/s	kW	mm	mm	mm	kg
20075	2100	750	1600	400	520	270	830	150	10	100	11	2910	1735	2735	5600
25075	2600	750	2100	400	520	270	830	150	10	100	11	3840	1735	2735	6800
30075	3100	750	2600	400	520	270	830	150	10	100	11	4340	1735	2735	7700
25100	2600	1000	2100	400	520	270	920	200	10	125	11	3450	1760	2930	7200
30100	3100	1000	2600	400	520	270	920	200	10	125	11	4340	1760	2930	8400
36100	3660	1000	3150	400	520	270	920	200	10	125	11	4900	1760	2930	10400
40100	4100	1000	3150	400	520	270	920	200	10	125	11	5340	1760	2930	10600
43100	4300	1000	3750	400	520	270	920	200	10	125	11	5540	1760	2930	11800
25150	2600	1500	2100	400	520	270	920	200	10	125	15	3840	1760	2930	7800
30150	3100	1500	2600	400	520	270	920	200	10	125	15	4410	1760	2930	9200
36150	3660	1500	3150	400	520	270	970	200	10	125	15	4900	1760	2930	11000
40150	4100	1500	3150	400	520	270	970	200	10	125	15	5350	1760	2930	11200
43150	4300	1500	3750	400	520	270	970	200	10	125	15	5540	1760	2930	13200
25200	2600	2000	2100	400	520	270	920	160	8	120	18.7	3840	2060	2920	9600
30200	3100	2000	2600	400	520	270	920	160	8	120	18.7	4340	2060	2920	10700
36200	3660	2000	3150	400	520	270	920	160	8	120	18.7	4900	2060	2920	12200
40200	4100	2000	3150	400	520	270	920	160	8	120	18.7	5400	2060	2920	13100
43200	4300	2000	3750	400	520	270	920	160	8	120	18.7	5540	2060	2920	16400
30250	3100	2500	2600	400	520	270	895	130	8	90	18.7	4340	2250	2920	13000
36250	3660	2500	3150	400	520	270	895	130	8	90	18.7	4900	2250	2920	13900
40250	4100	2500	3150	400	520	270	895	130	8	90	18.7	5400	2250	2920	15300
43250	4300	2500	3750	400	520	270	895	130	8	90	18.7	5540	2250	2920	16700
50250	5000	2500	4050	400	520	270	945	130	8	90	18.7	6240	2250	2920	23800
60250	6000	2500	5050	400	520	270	1090	130	8	90	18.7	7240	2250	2920	30500
30320	3100	3200	2600	400	620	420	895	100	8	95	22.5	4340	2210	3490	17000
36320	3660	3200	3150	400	620	420	895	100	8	95	22.5	4900	2210	3490	19500
40320	4100	3200	3150	400	620	420	895	100	8	95	22.5	5340	2210	3490	21000
43320	4300	3200	3750	400	620	420	895	100	8	95	22.5	5540	2210	3490	23000
50320	5000	3200	4050	400	620	420	940	100	8	95	22.5	6240	2210	3490	27500
60320	6000	3200	5050	400	620	420	1095	100	8	95	22.5	7240	2210	3490	32500
30400	3100	4000	2600	400	620	420	1045	90	7	60	37.5	4080	2570	3950	26000
36400	3660	4000	3150	400	620	420	1045	90	7	60	37.5	4640	2570	3950	29000
40400	4100	4000	3150	400	620	420	1045	90	7	60	37.5	5080	2570	3950	31000
43400	4300	4000	3150	400	620	420	1045	90	7	60	37.5	5280	2570	3950	32000

Specifications subject to modifications without prior notice

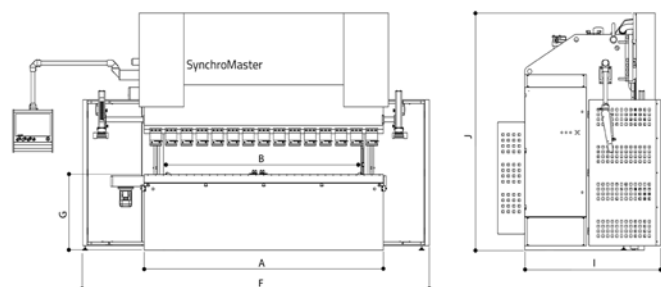
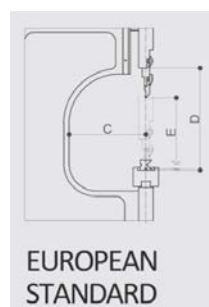

SynchroMaster

EasyBEND-2D MT (Optional)

EasyBEND-2D MT control

- 18.5" multi colour Multi Touch screen
- Standard 2D visualisation
- Automatic or manual bending
- Execution of generated 2D-programs
- USB interface
- Network + offline functions
- Multi-language support
- Remote diagnostics

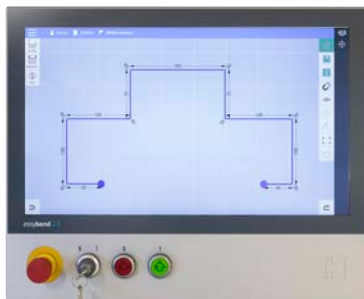

Point to Point drawing method & Real Time solution calculation during building up the workpiece design



SMART DRAFT: innovative drawing method for generating 2D workpieces



STEP PREVIEWER: bar with possibility of horizontally scrolling of the bending steps



COMBINED ICONS: multiple functionalities by means of one single icon



Intuitive Interface with combined numerical-graphical user interface



Intuitive Interface with program overview and possibility of operator messages

SynchroMaster

Optional equipment



X-R BACKGAUGE

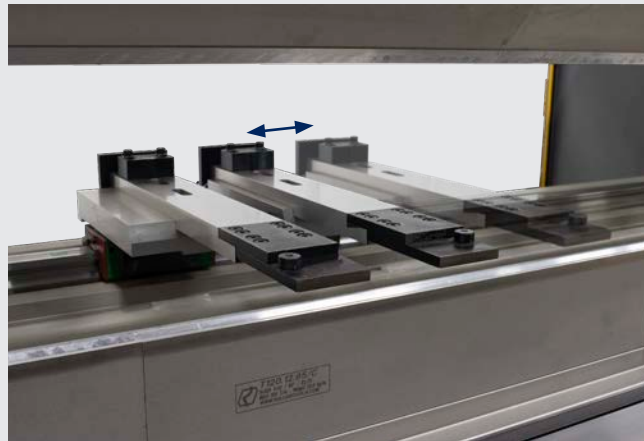

**X-R-Z/Z' AND X-R-Z1-Z2
BACKGAUGES**

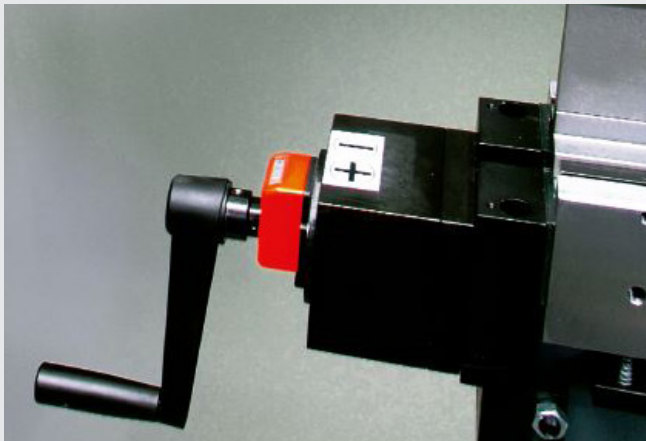

MANUAL CROWNING

Manual Anti-Deflection table for European Standard Bottom tooling

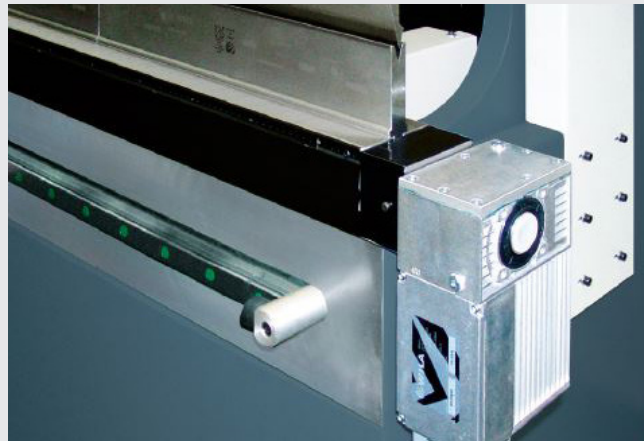

CNC CROWNING

Motorised CNC controlled anti-deflection table for European Standard and single V-dies

SynchroMaster

Optional equipment

FRONT STOP TYPE I

2 units, length 750 mm, with T-slot and 1 tilting stop.

Movable along the working length of the machine, manually adjustable in height.



OPTICAL SAFETY GUARDS DSP AND FIESSLER AKAS® LC-II M

The CE regulation allows only Fast Approach Speed when applying an optical safety guard moving with the closing beam.

This guard is mounted to the beam and can be adjusted manually in height.

When detecting an obstacle within the protected area around the tip of the upper tooling, the system interrupts the downward movement instantaneously.

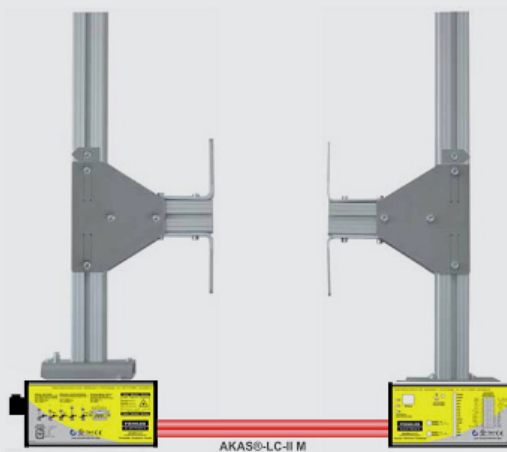

EuroMaster-S Series

Your allround bending machine

BEAM CONTROL

Beam parallelism and depth stop setting by means of bed referenced linear encoders for accurate beam position measurement, synchro module and proportional valve hydraulics

INTUITIVE FASTBEND-2D MT PREMIUM CONTROL

- Multi Touch Technology on 21.5" screen
- Intuitive Operator Interface
- Smart Draft
- Multi-Tasking
- Step Previewer
- Combined Icons
- Auto Tooling
- Pendant arm with optional height adjustment



EUROPEAN STANDARD TOP TOOLING WITH QUICK MANUAL CLAMPING

New Standard Top and Bottom Tooling (optional)



*Model 40250
Flush Floor frame
design for all models*



**ROL1 CLAMP3
(optional)**

EuroMaster-S Series



CROWNING TABLE

Compensates for ram and table deflection, ensuring consistent bending angles over the entire bending length. Standard CNC controlled (V-axis).

2-AXES X-R BACKGAUGE

Rigid and High Speed backgauge for accurate sheet positioning

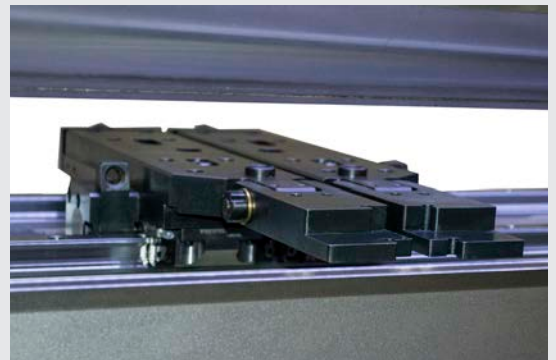

2 SHEET SUPPORTS WITH GUIDING



ROL200 Manual or Pneumatic (optional)

EuroMaster-S Series

Standard Execution



INTUITIVE FASTBEND-2D MT PREMIUM CONTROL

The application of Multi Touch technology reduces the number of keyboard- and button actions to an absolute minimum. The innovative Smart Draft, Design/Bending Multitasking, Step Previewer and Combined Icons features allow the operator a straightforward, intuitive control of the entire production cycle.



EUROPEAN STANDARD (ES) TOP TOOLING with

Quick Manual Clamping arrangement and CNC controlled Anti Deflection Table with clamping for ES dies

The European Standard Tooling System has proven its flexibility, affordability and precision during the last decades in an infinite number of sheet metal working shops. A wide choice of a vast number of top and bottom tools allows for an unpredictable number of applications in various materials and thicknesses.



HIGH SPEED X-R-BACKGAUGE

A rigid and accurate backgauge is an absolute condition for precision. High speed is an absolute condition for production output and short cycle times. The EuroMaster's X-R backgauge (and optional X-R-Z/Z' and X-R-Z1-Z2 versions) offers both. Manual finger width adjustment from the front.

EuroMaster-S Series

Standard Execution

- **FastBEND-2D MT Premium control**

Smart Draft + MultiTasking + Step Previewer + Combined Icons + Auto Tooling

21.5" Multi Touch screen

- **High Speed X-R Backgauge for accurate sheet positioning**

Stroke X = 800mm, maximum speed = 1000mm/s

Stroke R = 250mm, maximum speed = 250mm/s

- **European Standard (ES) top clamping with Quick Manual Clamping Arrangement**

- **Intermediate clamping with height 150mm (all models \leq 3200 kN),
height 120mm HD version (all models = 4000 kN)**

- **CNC controlled Anti Deflection Table (Crowning) for ES dies, including nute for clamping single-V dies**

- **2 Sheet Supports 750 mm with guiding, manually adjustable in height**

- **LED illumination of the bending area**

Your Competitive Edge

A. Outstanding Price-Performance Ratio

B. State-Of-The-Art User Friendly 2D Multi Touch Control

C. Highest Part Precision

EuroMaster-S Series

Technical Specifications

Daylight Opening - Stroke - Gap

	Basic European Standard (ES)			Option ES High Specs			Option New Standard (NS)			Option NS High Specs		
	Daylight Opening	STROKE	GAP	Daylight Opening	STROKE	GAP	Daylight Opening	STROKE	GAP	Daylight Opening	STROKE	GAP
	D	E	C	D	E	C	D	E	C	D	E	C
	mm	mm	mm	mm	mm	mm	mm	mm	mm	mm	mm	mm
750 kN	520	270	400	620	370	400	440	270	400	540	370	400
1000 kN	520	270	400	620	370	400	440	270	400	540	370	400
1500 kN	520	270	400	620	370	400	440	270	400	540	370	400
2000 kN	520	270	400	620	370	400	440	270	400	540	370	400
2500 kN	520	270	400	620	370	400	440	270	400	540	370	400
3200 kN	620	420	400	-	-	-	540	420	400	-	-	-
4000 kN	620	420	400	-	-	-	540	420	400	-	-	-

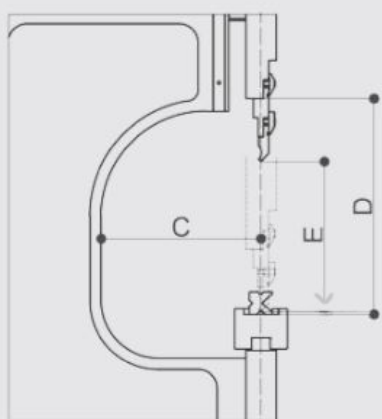

EUROPEAN STANDARD

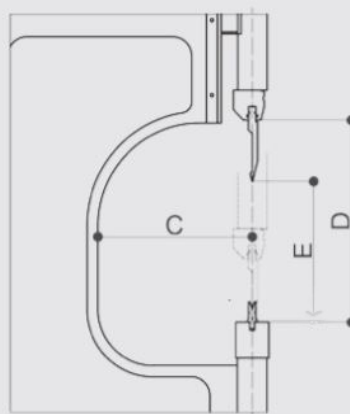

NEW STANDARD

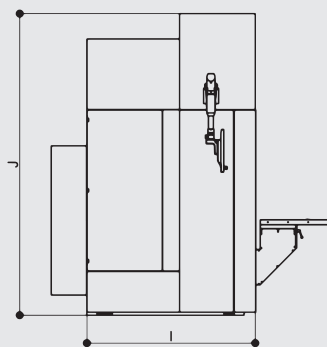
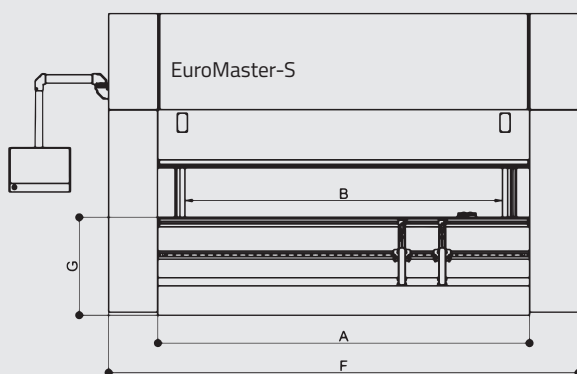

EuroMaster-S Series

Technical Specifications

(Valid for Basic European Standard)

	Bending length	Capacity	Distance between housings	Table Height	Fast Approach Speed	Max. Bending Speed	Fast Return Speed	Motor Power	Length	Width	Height	Weight
	A		B	G					F	I	J	
MODEL	mm	kN	mm	mm	mm/s	mm/s	mm/s	kW	mm	mm	mm	kg
20075°	2100	750	1600	920	150	10	100	11	3090	1585	2920	5900
25075°	2600	750	2100	920	150	10	100	11	3590	1585	2920	7500
30075°	3100	750	2600	920	150	10	100	11	4090	1585	2920	8000
25100°	2600	1000	2100	920	200	10	125	11	3590	1585	2920	7500
30100°	3100	1000	2600	920	200	10	125	11	4090	1585	2920	9300
36100°	3660	1000	3150	920	200	10	125	11	4500	1585	2920	10500
40100°	4100	1000	3150	920	200	10	125	11	5090	1585	2920	10800
43100°	4300	1000	3750	920	200	10	125	11	5280	1585	2920	12100
25150°	2600	1500	2100	920	200	10	125	15	3590	1705	2920	8400
30150°	3100	1500	2600	920	200	10	125	15	4090	1705	2920	10100
36150°	3660	1500	3150	970	200	10	125	15	4635	1705	2920	11600
40150°	4100	1500	3150	970	200	10	125	15	5105	1705	2920	11900
43150°	4300	1500	3750	970	200	10	125	15	5280	1705	2920	13500
25200°	2600	2000	2100	920	160	8	120	18.7	3590	1820	2920	10400
30200°	3100	2000	2600	920	160	8	120	18.7	4090	1820	2920	11200
36200°	3660	2000	3150	920	160	8	120	18.7	4500	1820	2920	12800
40200°	4100	2000	3150	920	160	8	120	18.7	5090	1820	2920	13700
43200°	4300	2000	3750	920	160	8	120	18.7	5280	1820	2920	16800
30250°	3100	2500	2600	895	130	8	90	18.7	4090	2020	2920	13200
36250°	3660	2500	3150	895	130	8	90	18.7	4635	2020	2920	14800
40250°	4100	2500	3150	895	130	8	90	18.7	5090	2020	2920	16200
43250°	4300	2500	3750	895	130	8	90	18.7	5280	2020	2920	17100
50250*	5000	2500	4050	945	130	8	90	18.7	6240	2250	3490	24300
60250*	6000	2500	5050	1090	130	8	90	18.7	7240	2250	3490	31000
30320*	3100	3200	2600	895	100	8	95	22.5	4340	2210	3490	17500
36320*	3660	3200	3150	895	100	8	95	22.5	4900	2210	3490	20000
40320*	4100	3200	3150	895	100	8	95	22.5	5340	2210	3490	21500
43320*	4300	3200	3750	895	100	8	95	22.5	5540	2210	3490	23500
50320*	5000	3200	4050	940	100	8	95	22.5	6240	2210	3490	28000
60320*	6000	3200	5050	1095	100	8	95	22.5	7240	2210	3490	33000
30400*	3100	4000	2600	1045	90	7	60	37.5	4080	2570	3950	26500
36400*	3660	4000	3150	1045	90	7	60	37.5	4640	2570	3950	29500
40400*	4100	4000	3150	1045	90	7	60	37.5	5080	2570	3950	31500
43400*	4300	4000	3150	1045	90	7	60	37.5	5280	2570	3950	32500

Specifications subject to modifications without prior notice

° Euromaster-S models with built-in side doors

* Euromaster-S models with free-standing side doors, SynchroMaster style (see drawing on page 8)

PressMaster Series

Your High Spec, High Performance bending machine

**INCREASED DAYLIGHT OPENING (540MM),
STROKE (370MM)**

BEAM CONTROL

Beam parallelism and depth stop setting by means of bed referenced linear encoders for accurate beam position measurement, synchro module and proportional valve hydraulics

INTUITIVE FASTBEND-3D MT PREMIUM CONTROL

- Multi Touch Technology on 24" screen
- Intuitive Operator Interface
- Smart Draft
- Multi-Tasking
- Step Previewer
- Combined Icons
- Auto Tooling
- PartManager-3D

NEW STANDARD HYDRAULIC TOP TOOL CLAMPING

LAZERSAFE OPTICAL SAFETY GUARD (optional)



PressMaster Series



*Model 36150
Flush Floor frame
design for all models*

CNC CROWNING TABLE WITH HYDRAULIC CLAMPING FOR NEW STANDARD BOTTOM TOOLING

Compensates for ram and table deflection, ensuring consistent bending angles over the entire bending length. CNC controlled (V-axis)

4-AXES X-R-Z1-Z2 BACKGAUGE

Rigid and High Speed backgauge for accurate sheet positioning



2 SHEET SUPPORTS WITH GUIDING



PressMaster Series

Standard Execution

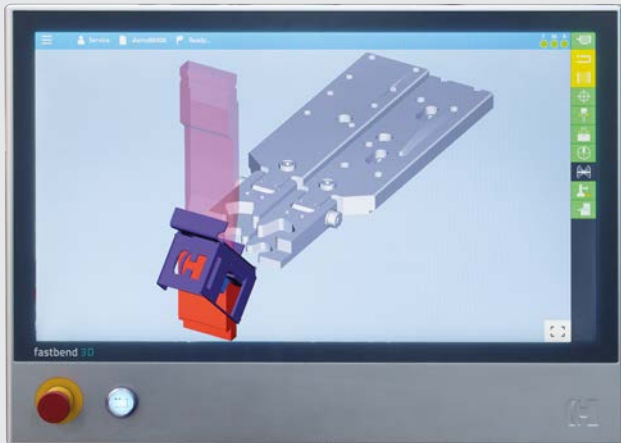

INTUITIVE FASTBEND-3D MT PREMIUM CONTROL

The application of Multi Touch technology reduces the number of keyboard- and button actions to an absolute minimum. The innovative Smart Draft, Design/Bending Multitasking, Step Previewer and Combined Icons features allow the operator a straightforward, intuitive control of the entire production cycle.

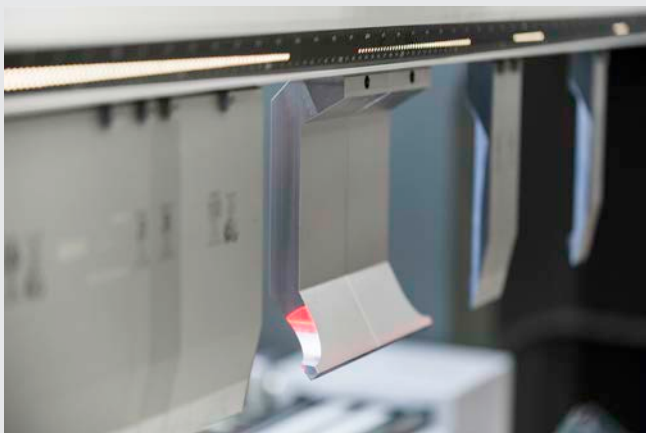

NEW STANDARD (NS)

hydraulic top tool clamping and CNC controlled Anti Deflection Table with hydraulic bottom tool clamping

The New Standard Tooling System has proven its flexibility and precision during the last decades in an infinite number of sheet metal working shops. A wide choice of a vast number of top and bottom tools allows for a unpredictable number of applications in various materials and thicknesses.



HIGH SPEED X-R-Z1-Z2 BACKGAUGE

A rigid and accurate backgauge is an absolute condition for precision. High speed is an absolute condition for production output and short cycle times. The PressMaster's X-R-Z1-Z2 backgauge offers both.

PressMaster Series

Standard Execution

- **FastBEND-3D MT Premium control**
 - Smart Draft + MultiTasking + Step Previewer + Combined Icons + Auto Tooling + Part Manager-3D
 - 24" Multi Touch screen
- **Increased Daylight Opening (540mm), Stroke (370mm) and Gap (400mm)**
- **Increased Fast Approach Beam Speed (up to 200mm/s) and Fast Return Speed (up to 170mm/s)**
- **High Speed X-R-Z1-Z2 Backgauge for accurate sheet positioning**
 - Stroke X = 800mm, maximum speed = 1000mm/s
 - Stroke R = 250mm, maximum speed = 250mm/s
 - Speed Z1 and Z2 axes = 1000mm/s
- **New Standard (NS) hydraulic top tool clamping**
- **CNC controlled Anti Deflection Table (Crowning) for NS dies**
- **2 Sheet Supports with guiding, manually adjustable in height**
- **LED illumination of the bending area**
- **Less Power Consumption through application of Variable Inverter Drive (= VID) for motor-pump unit.**

The VID technology allows for higher beam return speeds in combination with 'no power consumption with stationary beam.

Your Competitive Edge

A. Ultimate Price-Quality Ratio

B. State-Of-The-Art User Friendly 3D Multi Touch Control

C. Lowest Cycle Times

PressMaster Series

Technical Specifications

	Bending length	Capacity	Distance between housings	Gap	Daylight opening	Stroke	Table Height	Fast Approach Speed	Max. Bending Speed	Fast Return Speed	Motor Power	Length	Width	Height	Weight
	A		B	C	D	E	G					F	I	J	
MODEL	mm	kN	mm	mm	mm	mm	mm	mm/s	mm/s	mm/s	kW	mm	mm	mm	kg
20075	2040	750	1600	400	540	370	920	150	10	150	11	3090	1585	2910	6000
25075	2550	750	2100	400	540	370	920	150	10	150	11	3590	1585	2910	7700
30075	3060	750	2600	400	540	370	920	150	10	150	11	4090	1585	2910	8200
25100	2550	1000	2100	400	540	370	920	200	10	170	11	3590	1585	2980	8100
30100	3060	1000	2600	400	540	370	920	200	10	170	11	4090	1585	2980	9600
36100	3655	1000	3150	400	540	370	920	200	10	170	11	4500	1585	2980	10800
40100	4080	1000	3150	400	540	370	920	200	10	170	11	5090	1585	2980	11700
43100	4250	1000	3750	400	540	370	920	200	10	170	11	5280	1585	2980	12800
25150	2550	1500	2100	400	540	370	920	200	10	170	15	3590	1705	2980	8700
30150	3060	1500	2600	400	540	370	920	200	10	170	15	4090	1705	2980	11000
36150	3655	1500	3150	400	540	370	970	200	10	170	15	4640	1705	2980	12000
40150	4080	1500	3150	400	540	370	970	200	10	170	15	5090	1705	2980	13100
43150	4250	1500	3750	400	540	370	970	200	10	170	15	5280	1705	2980	14600
25200	2550	2000	2100	400	540	370	920	160	8	170	18.7	3590	1820	2980	10800
30200	3060	2000	2600	400	540	370	920	160	8	170	18.7	4090	1820	2980	12000
36200	3655	2000	3150	400	540	370	920	160	8	170	18.7	4500	1820	2980	13100
40200	4080	2000	3150	400	540	370	920	160	8	170	18.7	5090	1820	2980	13900
43200	4250	2000	3750	400	540	370	920	160	8	170	18.7	5280	1820	2980	17000
30250	3060	2500	2600	400	540	370	895	130	8	90	18.7	4090	2020	2980	14200
36250	3655	2500	3150	400	540	370	895	130	8	90	18.7	4500	2020	2980	15500
40250	4080	2500	3150	400	540	370	895	130	8	90	18.7	5090	2020	2980	16400
43250	4250	2500	3750	400	540	370	895	130	8	90	18.7	5280	2020	2980	17900

Specifications subject to modifications without prior notice

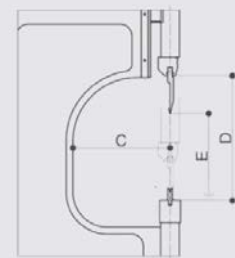
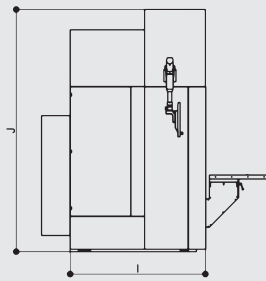
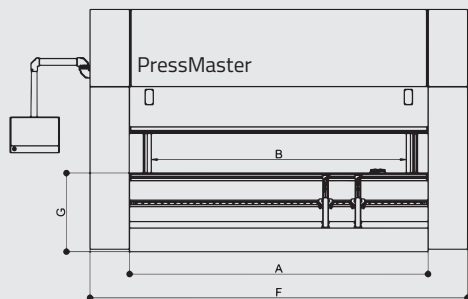

NEW STANDARD

Backgauges

Standard and optional



X-R-Z1-Z2 (standard*)

Stroke **X** = 800 mm

Max. Speed X = 1000 mm/s

Stroke **R** = 250 mm

Max. Speed R = 250 mm/s

Max. Speed Z1-Z2 = 1000 mm/s

* optional on EMS models, standard on PM models



X-R-Z1-Z2-X3 (optional)

Stroke **X** = 800 mm

Max. Speed X = 1000 mm/s

Stroke **R** = 250 mm

Max. Speed R = 250 mm/s

Max. Speed Z1-Z2 = 1000 mm/s

Stroke **X3** = -50/+50 mm

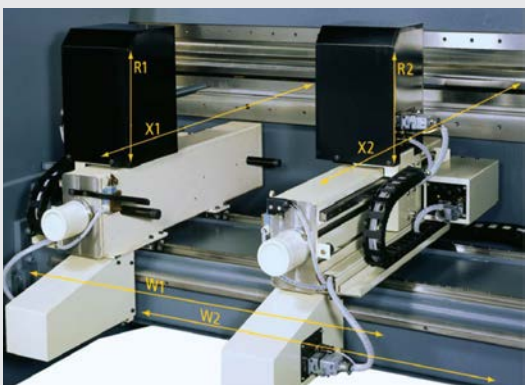

X1-X2-R1-R2-W1-W2 (optional)

Stroke **X1-X2** = 600 mm

Stroke **R1-R2** = 135 mm

FastBEND-2D/3D MT Premium

Intuitive Bending

The **FastBEND-2D/3D MT Premium** Controls set a new standard in the market for flexible, reliable and high precision sheet metal bending.

Driven by **state-of-the-art PC-based hardware**, the system allows for very fast data processing and highly accurate calculation of the optimal bending programs for hydraulic CNC press brakes.

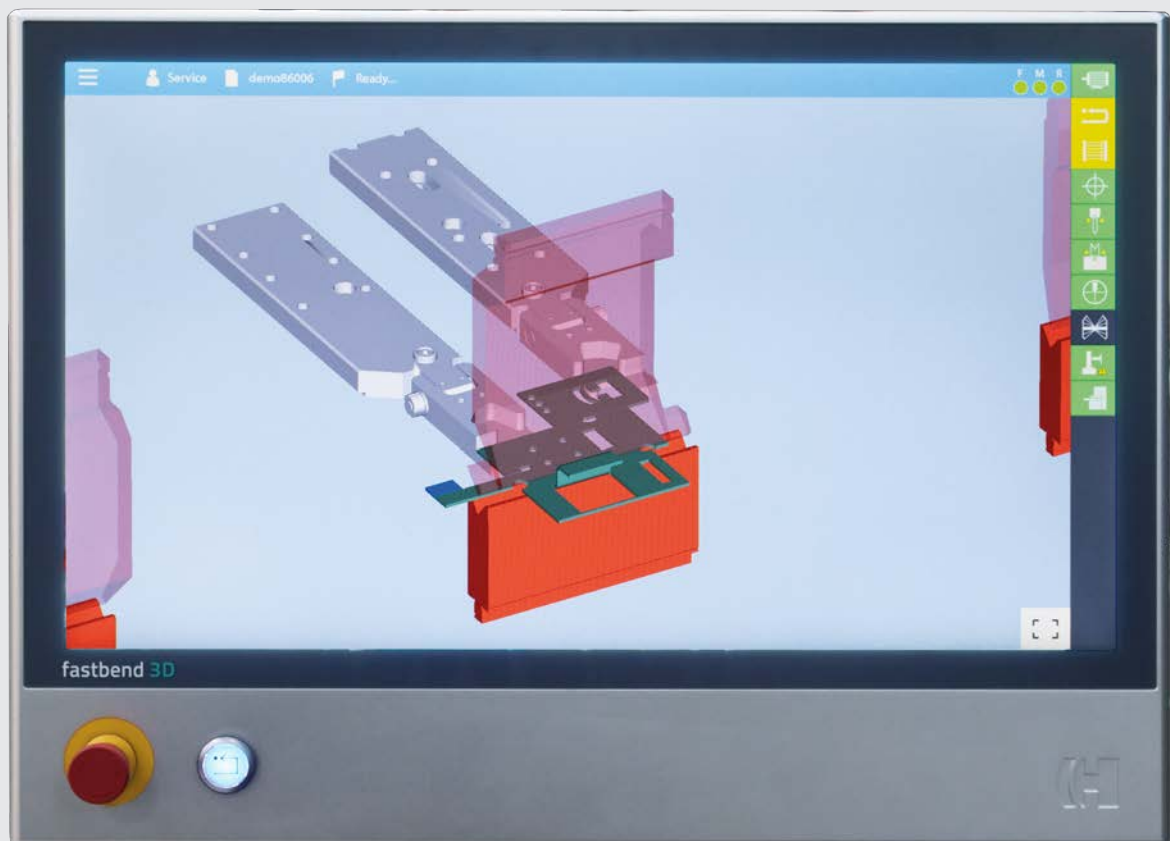

FastBEND-2D/3D MT Premium

Intuitive Bending

Intuitive Interface with a minimum of interactions to draw the workpiece and generate the corresponding program

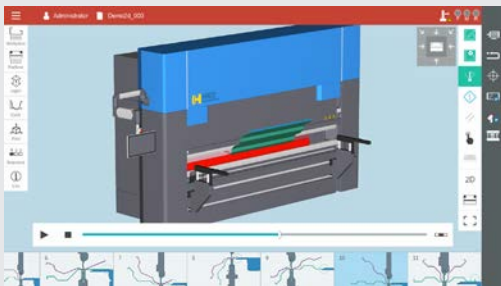

Multi Touch Technology on
24" screen (FastBEND-3D MT Premium)
21,5" screen (FastBEND-2D MT Premium)



Intuitive Interface with combined numerical-graphical user interface

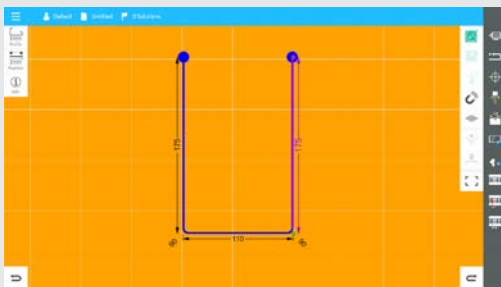

MULTITASKING : workpiece drawing with instantaneous collision detection and calculation of the bending sequence in the background

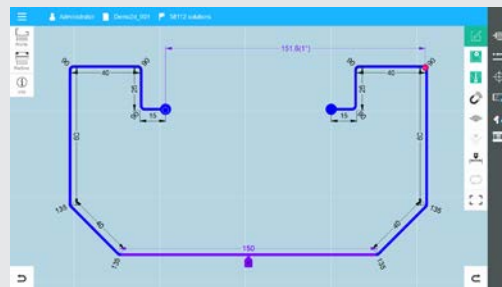

Point to Point and SMART DRAFT : innovative drawing methods for generating 2D workpieces

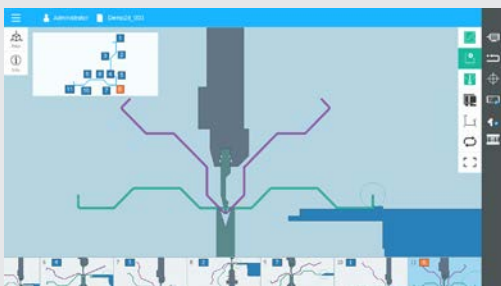

STEP PREVIEWER : bar with possibility of horizontally scrolling of the bending steps

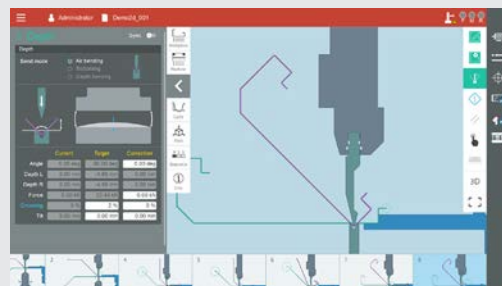

COMBINED ICONS : multiple functionalities by means of one single icon

New Standard Tooling System

Standard for PressMaster, Optional for EuroMaster-S

Wila's 'New Standard' Tooling System has become market leader for precision, quality and flexibility. The selfseating and selfaligning features considerably improve your set up times and productivity of your press brake. Both bottom (OZU) and top (BIU) tooling are clamped hydraulically. The bottom clamping is integrated in the crowning table.

New Standard tooling is safe: the Safety-Click system (for top tools up to 12,5 kg) enables vertical loading and unloading of your top tooling without any risk. For tools with bigger weight, a safety pin or key is applied.

Working surfaces and bending radii of New Standard tooling are hardened and precision ground for maximum longevity.

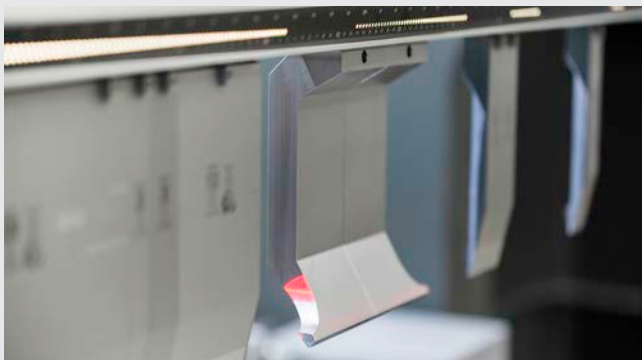

MAIN BENEFITS

1. Vertical loading and unloading

2. Self-seating and self-aligning

3. High precision and longevity

Optional Smart Tool Locator

Increase your press brake productivity

The **Smart Tool Locator (STL)** further increases your press brake productivity. The system indicates by means of built-in LED's the right clamping position of your tooling during tool set up and indicates the active tool location in production mode. The Smart Tool Locator offers significant benefits in **speed, precision** and **flexibility**.

Available for all hydraulic New Standard Tool Holders for top and bottom tools.



NEW STANDARD PREMIUM AND PRO TOOLING

Both top (BIU) and bottom (OZU) tools are available in a wide variety of shapes and dimensions. For more detailed information, see the New Standard Tooling Catalogue.

Available for all hydraulic New Standard Tool Holders for top and bottom tools.

Sheet Following Systems

For bending long and thin sheets

Sheet Following Systems are especially recommended when bending **long** and **thin** sheets as they support as well as prevent second bends in your part.

They are very efficient in **supporting heavy parts** during decompression and beam return movement.



The Sheet Following Units are operating electro-mechanically by means of servo motors, with adjustable speed as a function of the applied V-opening.

They can be adjusted vertically in order to suit different die heights.

Picture below:

Special Customized Sheet Following System with 1 telescopic arm inclusive width adjustment of the support surface and height adjustment of the following arm.



Lazersafe Optical Safety Guards

Advanced Safety

CE Safety Regulations require the application of an **Optical Safety Guard (OSG)** when operating at closing speed.

Optical modules (transmitter and receiver) mounted to the ram of the machine monitor the downward movement in the area underneath the top tooling tip. During the fast closing speed, the beam movement is instantaneously stopped when the system detects an obstacle.

EuroMaster-S and PressMaster can be equipped with **LazerSafe LZS-LG-HS** with mute point 6mm (RapidBend) or with **LazerSafe IRIS** (RapidBend Ultimate) with mute point 0 mm.

BOTH SYSTEMS GUARANTEE

a high level of safety for the operator

a high level of machine productivity

security against tooling collision at high speeds

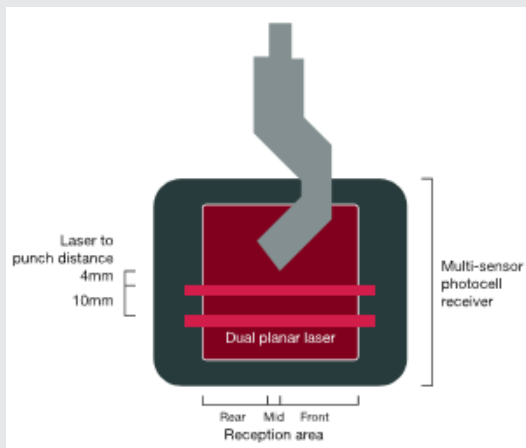

Lazersafe LZS-L6-HS

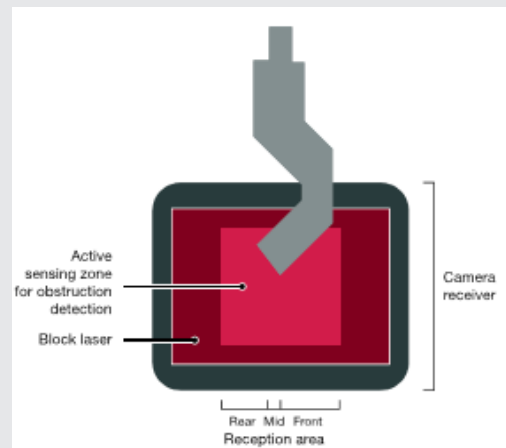

Lazersafe IRIS



EMS



PM

Lazersafe Optical Safety Guard IRIS Features

- Optimal Speed Change Over Point
- Fast Closing Speed in safe conditions (monitoring till mute point 0 mm)
- Faster cycle times
- Ultimate Operator Safety
- Security against tooling damage
- Full Integration in the CNC System
- Automatic Alignment

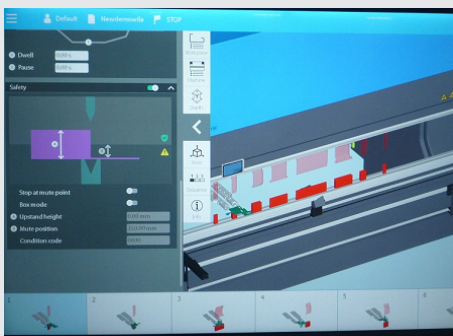

NORMAL MODE

All sensors + 3 zones active
Fast Approach Speed till mute point
Followed by Working Speed
(unless interruption by obstacle)



BOX MODE WITH PROGRAMMABLE FLANGE HEIGHT

Programmable flange height
Extra deliberately foot pedal command
Front and Rear zone switched off at flange height



MUTE STOP MODE

Applicable for workpieces with flanges which interrupt the monitored zone in normal mode operation.
Initial fast approach till mute point, consequently operator infeed of the workpiece.

Angle Measuring System Alfa-F

Angle Measurement



EMS



PM

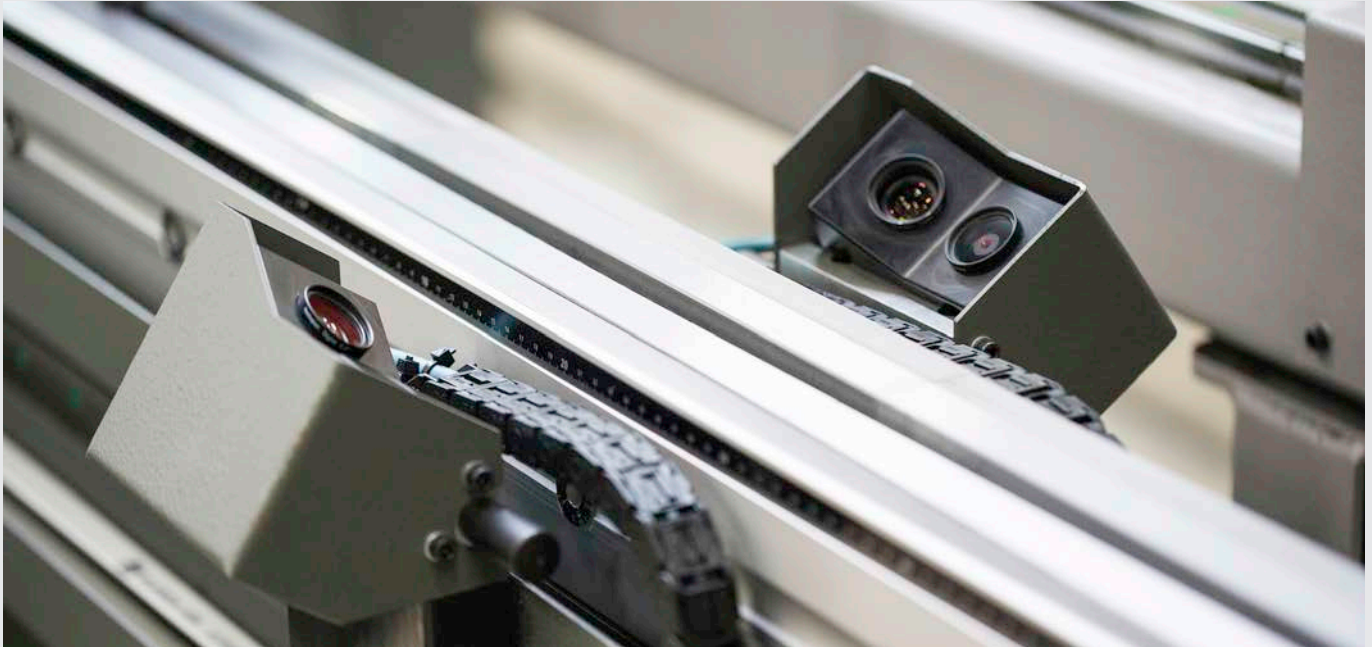

System consisting of 2 laser beam transmitters and 2 camera's on both sides of the workpiece.

Principle :

Angle Measurement

Force reduction + calculation of the springback

Automatic angle correction (taking into account the calculated springback)

FEATURES ALFA-F

- Different V-openings and dies are applicable, preferable single-V's with minimal height of 100mm
- Quick manual adjustment along the machine length (optional CNC-positioning)
- Optional parking station if system is not in operation

FEATURES ALFA-F AND IRIS PLUS

- Standard tooling is applicable - no extra cost for internal measuring units
- No contact elements - no mechanical wear
- Contactless angle measurement principle guarantees a reliable system even in heavy duty circumstances.



EMS



PM

Angle Measuring System IRIS Plus

Angle Measurement

Automatic angle measurement and automatic correction of the bending angle



Active Angle control is a highly accurate angle control process that calculates spring back for each individual bend, then controls the bend depth with Live Angle Bending to achieve the correct angle.

IRIS Plus comprises a laser transmitter and receiver set mounted to the upper beam of the press brake. It includes a high speed digital camera and image data processing system contained within the receiver unit.



FEATURES IRIS PLUS

- Different V-openings (8 until 35 mm) are applicable, limited to single-V dies
- Recommendable limitation on the working length: ca. 3600 mm
- Optimal accuracy for 3 meters or less bending length
- No collision with workpiece

FEATURES ALFA-F AND IRIS PLUS

- Compact assembly guarantees an optimal working space for operator and material
- Possibility of measuring on workpieces with apertures
- Guaranteed precision

Robot Bending

Standardized cells

Haco offers standard as well as customised robot bending solutions for a diverse range of applications. Being a pioneer in this field, we offer systems where the complete cell is controlled by one control with both in-house hardware and software technology. Our standard robot bending cells feature press brake specifications from 900mm x 220kN up to 4000mm x 2000kN and part specifications from 300 x 300 mm x 3 kgs up to 3600 x 400 mm x 70 kgs.

Customised systems can be offered for press brake and part specifications well outside the standard ones.

Depending on the characteristics of the application, the robot is selected from reputed manufacturers such as Yaskawa, Stäubli, Fanuc and others.

Robot supported bending has become cost effective even for small and medium size batches as CAM and Simulation Software have become very powerful and user-friendly, reducing considerably programming and set-up times and offering full off-line automatic work preparation avoiding standstill of the bending cell.

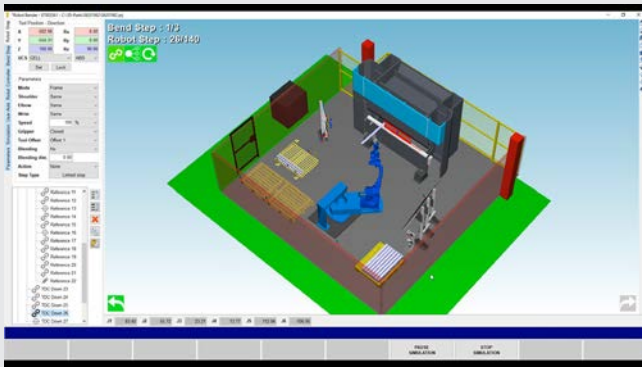

SOFTWARE : User-friendly offline software for both robot and press brake

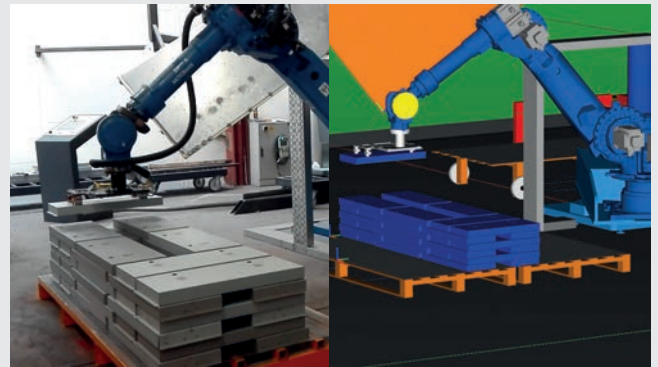

REAL VS SIMULATION : Our software solutions offer realistic and useful transition from simulation to reality. (robot positioning for bending)

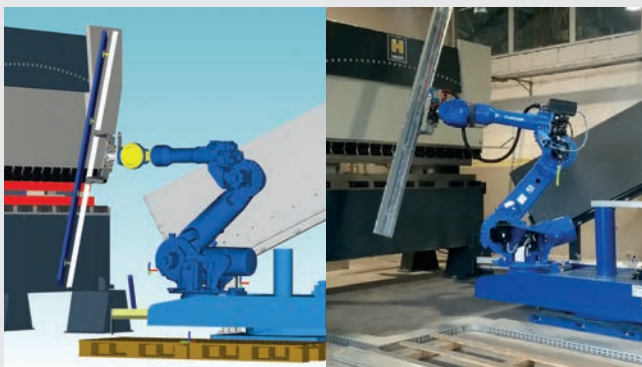

REAL VS SIMULATION : Our software solutions offer realistic and useful transition from simulation to reality. (robot positioning for bending)



ROBOT BENDING : Provides large gains in efficiency in large batch production of all types of parts.



EMS



PM

Robot Bending Turnkey Projects

The software deals with all aspects such as digital part input, 3D part unfolding, bending sequence and collision analysis, bending tooling selection, robot handling and bending path determination, press brake program, stacking of finished components, etc... We offer a complete cell, including peripheral equipment such as alignment tables, customised workpiece grippers, automatic gripper- and tooling change arrangements, CE safety specifications and advice for any aspect of the logistics of base plates and finished work pieces.

Robot cells can be extended with rotary tables and linear rails to increase the robot range when e.g. applying press brakes with longer bending lengths.

Additional robots (cobots) increasing efficiency of the bending cell can be added, performing 'out-bending-cycle' operations such as pick, place and preparation of base plates; double sheet detection; etc...

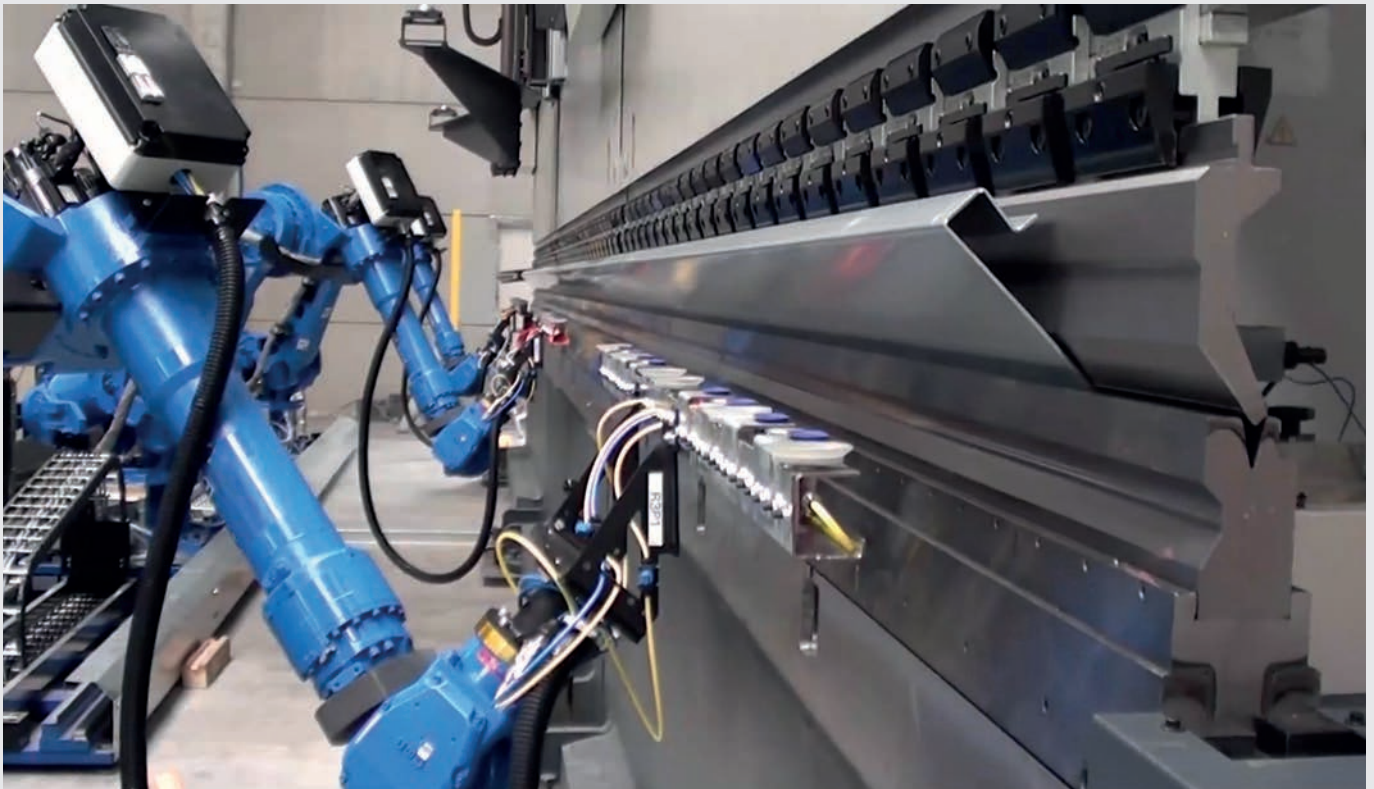

SINGLE, TANDEM OR TRIDEM: Robot bending offers exceptional benefits for large -hard to handle - parts. Ideal for combination in tandem or tridem press brake setup.

Tandem/Tridem Bending Systems

For bending long sheets

HACO offers **customised tandem and tridem solutions** for applications where long bending lengths are combined with moderate tonnage requirements. In a tandem solution, two press brakes are combined in a flush floor set-up with double bending length and double tonnage, saving in foundation cost.

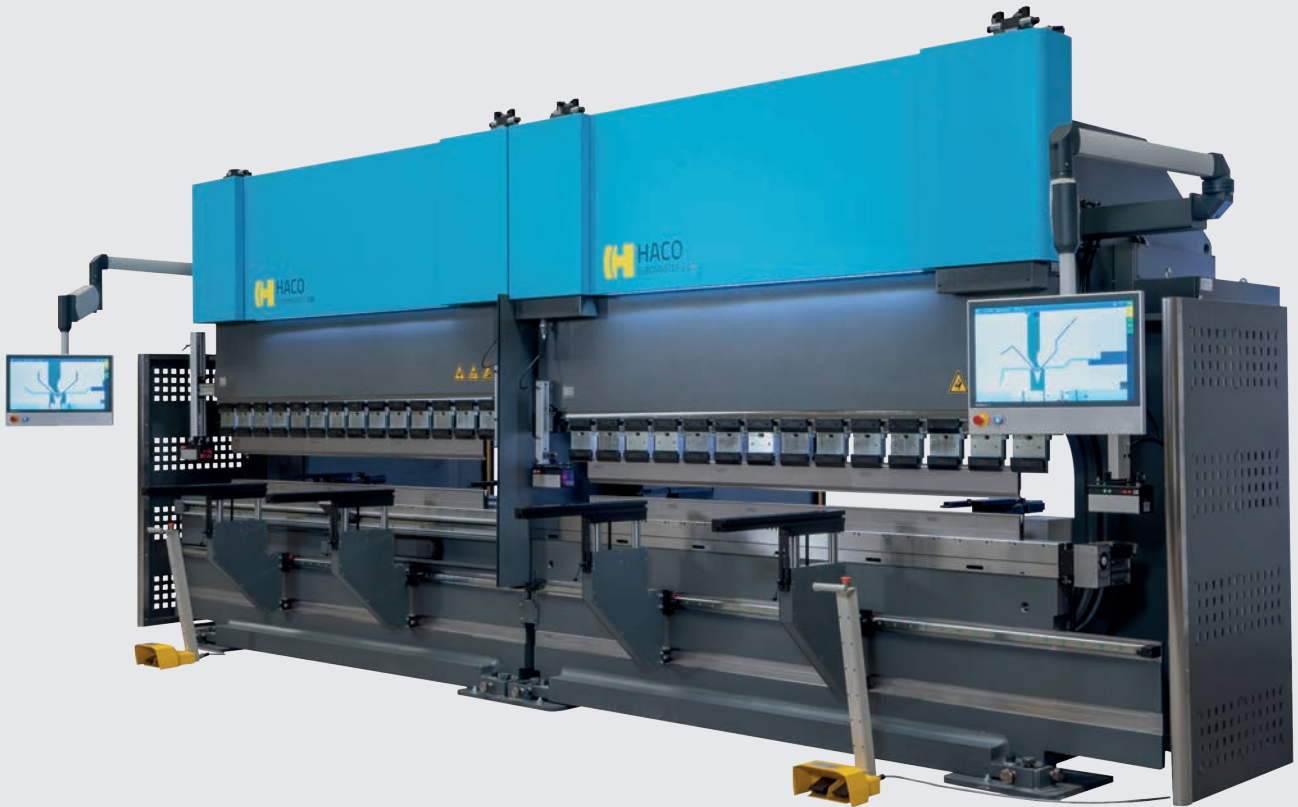

Tandem configurations are an alternative for single unit press brakes that often require high foundation costs.

A tandem press brake combination can be operated as **two single machines** with two operators executing different jobs or **combined in tandem** operation with two operators forming one single large sheet metal part.

A tandem press brake set-up generally doesn't require a complicated and expensive foundation. Both machines are positioned next to each other, each as a single machine, but offering double length and double capacity. Tandem press brakes are executed with deep throat depths to **allow full length parts with big flange lengths**.

HDSY Press Brakes

Heavy Duty SYnchro Bending Systems

HDSY (Heavy Duty SYnchro) press brakes are applied for heavy duty bending applications, requiring high tonnages and/or long bending lengths. These press brakes are p.e. required to bend thick plates of High Tensile materials, requiring several hundreds of tons bending force per meter bending length.

HDSY press brakes are offered in a range of **tonnages from 4000kN up to 20000kN** and **bending lengths from 3000mm up to 10000mm.**

HDSY press brakes feature a rigid frame structure combined with **advanced synchro technology** to allow high precision leveling and depth setting of the bending beam. Such, in combination with CNC controlled **Anti-Deflection Table solutions**, a consistent and precise bending angle is guaranteed over the full length. Precise positioning of the workpiece is obtained by means of a wide selection of rigid CNC controlled back gauge configurations.

Depending on your bending application, we advise required specifications and execution of your machine, as well as special top and bottom tooling to **suit your needs.**





Robot Bending



Fiber Laser Cutting



Punching

HACO NV

Oekensestraat 120
8800 Roeselare
Belgium
T +32 (0) 51 26 52 00
E-Mail: info@haco.com
www.haco.com

WWW.HACO.COM

**SynchroMaster
EuroMaster-S
PressMaster**

For Impressive Performances