

### GANG-TOOL

(CUTTING TOOL, IDx1, ODx3)

- Low cost and compact configuration.
- Long X-axis traverse, 5~6 tools, and 30M feed rate, can offer quick and high precision machining job.
- Auxiliary tool plate available for quick tool-set change.
- Load/Unload system available

### 8-TOOL TURRET+GANG-TOOL

- Gang-tool slide can be mounted up to 12~13 tools totally available when with 8-tools turret .
- Auxiliary tool plate available for quick tool-set change.
- Load/Unload system available.
- High pressure pump available.

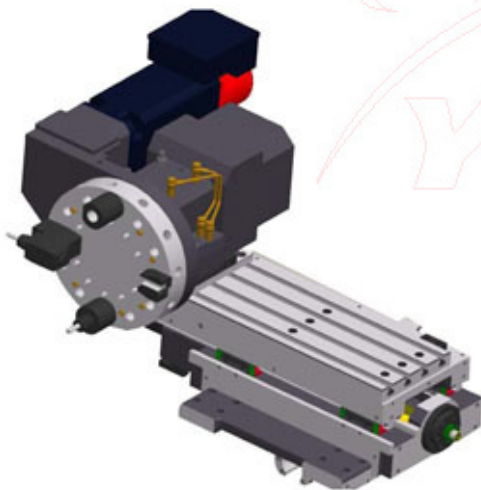

### 12-TOOL T+GANG TOOL

- The slide plate for gang-tool can also mount 12-T power turret at 5000 rpm, totally 15~16 tools.
- Offer CS-axis for turn-mill machining job.
- Load/Unload system available.
- High pressure pump available.

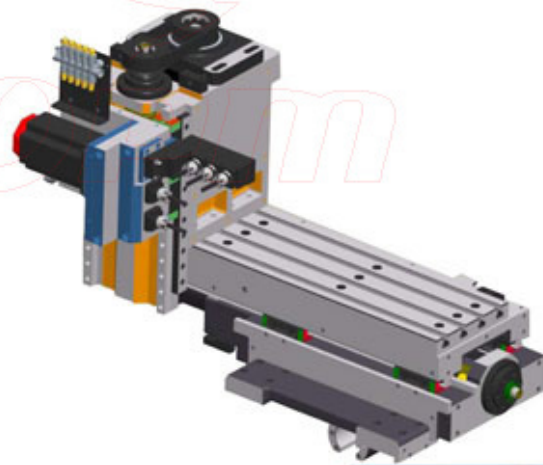

### Y-AXIS POWER TURRET+GANG TOOL

- The slide plate for gang-tool can mount 5-tool for Y-axis power turret at 4000 rpm, totally 9~10 tools.
- Offer CS-axis for turn-mill machining job.
- Load/Unload system available.
- High pressure pump available.