

Pinnacle
Since 1976



Pinnacle Machine Tool Co., Ltd.

No. 149, Sec. 1, Goufeng Rd., Shengang Dist.,
Taichung City 42949, Taiwan
TEL:886-4-25252995
FAX:886-4-25252991
E-mail:info@pinnacle-mc.com
<http://www.pinnacle-mc.com>

All Aspect
Machine Tool Manufacturer

2016 .11.1000-5



Taking the LEAD on Technology & Ecology

As a member of the global village, Pinnacle continues to further their technical innovations, the factors of environmental protection are also take into account in our design department.

Pinnacle Criteria

Among so many machine tool manufacturers in Taiwan, how can you tell the differences between one and the other? What are the criteria of "high quality", "high performance"., those words, always found in every big and small company's catalog?

At Pinnacle, our criteria are not just numbers defined in ISO, VDI or JIS. Our ultimate standard cannot be valued by numbers, it is our ATTITUDE:

The attitude of endlessly pursuing perfection, first-class before / after sales services, and the most appealing price-performance ratio machines.

Our devotion to technical research is the solid foundation allowing each Pinnacle machine to carry iron clad quality assurance. The proven quality of Pinnacle machines is made to meet your advanced technology needs, especially for your customers in high tech industries.

Our biggest reward is your satisfaction with Pinnacle machines, eventually bringing you remarkable profit and reputation.

General Manager
Allen Hsieh



Pinnacle

"exceeds your expectation"
Each Pinnacle Machine is Made from our Heart.



WIDE PRODUCT RANGE

Pinnacle Machine Tool Co., Ltd. was founded in 1976. With excellent experience in **Technology, Quality & Service**; we are specialized in manufacturing all kinds of machining centers such as 5-axis, double column, vertical, and horizontal. Furthermore, we have a wide range of CNC lathes as well. The complete product lines with outstanding quality satisfy the needs of our valuable customers worldwide.

STRONG TECHNICAL SUPPORT & AFTER SERVICE

R&D is teamed up with experienced engineers with decades of expertise in the machine tool industry. By means of applying up-to-date technologies such as CAD/CAM/CAE software and Finite Element Analysis, our machines are robustly constructed, assuring optimum rigidity and stability. Our reliable partnerships with dealers keep us connected closely with the latest technologies and market trends, hence ensuring Pinnacle product developments are upgraded constantly.

Well-trained service engineers are familiar with each step of assembly to ensure our quality service works and keep all machines running in the best status. Training courses to service engineers are held periodically to keep the team refreshed with the latest technology and skills.

Pinnacle's reputation is built on quality; it relies on an excellent quality control system and systematic management. The in-coming parts are inspected under highest standard by using precision equipment during production, assembly and final test run processes.

The sales and service departments provide customers pre-sale and after-sale services. Prompt reaction is our attitude to all customers, accurate and effective technical solutions are provided within the shortest time.



5 Axis MACHINING CENTER

AX series



AX series
5-axis machining on small-medium sized work pieces.

- ISO40 spindle.
- Integrated A-axis tilting and C-axis rotary table.
- A axis tilting: 150° (-120° to +30°)
- C axis rotary: 360°.
- Table size Ø170 / Ø320 / Ø450 / Ø500.
- 10000 or 12000 / 15000 rpm direct drive spindle (opt.)
- 20000rpm or 24000rpm Built-in spindle (opt.)
- High speed roller linear guideways.

5 Axis MACHINING CENTER

BX series

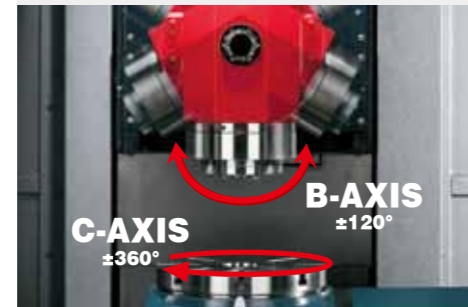

BX series
5-axis machining on large or heavy work pieces.

- ISO40 spindle.
- Detachable C axis: BX300A / 500A / 700A / 900A.
- Integrated direct drive C axis with rectangular table: BX500 / BX700 / BX900.
- B axis swiveling: 240° (-120° to +120°)
- C axis rotary: 360°.
- Standard built-in spindle: 15000 rpm.
- High speed roller linear guideways.
- B axis Direct Drive: BX500DD / BX700DD / BX900DD
- C axis with Turning function: BX700T / BX900T

DOUBLE COLUMN MACHINING CENTER

DV series



DV series
Immense Strength with One Piece Gantry

- ISO40 or ISO50 spindle.
- Machine columns and cross beam are made from one piece Meehanite cast iron.
- Unique linear guideways' deployment on Y axis beam.
- Spindles are all gear head driven.
- Spindle speed range: 8000 rpm.
- X-axis range is 1700–4200mm.
- Y-axis range is 1400–2100mm.
- Optional angle heads, extension head, boring / milling heads are available.
- Automatic head changer (Opt.)

VERTICAL MACHINING CENTER

Box Guideways

QVSV series



QV series
Heavy Duty with Versatility

- Available with ISO40 or ISO50 spindle.
- 4 slideways on the machine base for heavy duty purposes.
- Hardened box guideways.
- Spindle speed range: 8000 - 15000 rpm (ISO40), 6000 rpm (ISO50)
- X / Y ranged from 1140 x 710 to 2000 x 900 mm.
- Different spindle configuration for wide selection (belt, direct drive, and gearbox)

SV series
Classic Vertical Machining Centers

- Available with ISO40 or ISO50 spindle.
- Hardened box guideways.
- Spindle speed range: 8000 -12000 rpm (ISO40), 6000-8000 rpm (ISO50)
- X / Y ranged from 850 x 560 to 1300 x 610 mm.
- Different spindle configuration for wide selection (belt, direct drive, and gearbox)

VERTICAL MACHINING CENTER

Linear Guideways

LV series



LV series
Rapid and Smooth

- Available with ISO40 or ISO50 spindle.
- High speed roller linear guideways.
- Optimum structural design.
- Spindle speed range: 8000 -15000 rpm (ISO40), 6000 rpm (ISO50)
- X / Y ranged from 850 x 560 to 2000 x 900 mm.
- Different spindle configuration for wide selection (belt, direct drive, and gearbox)
- LV85 is available with Auto Pallet Changer. (Opt.)

HORIZONTAL MACHINING CENTER

LH series

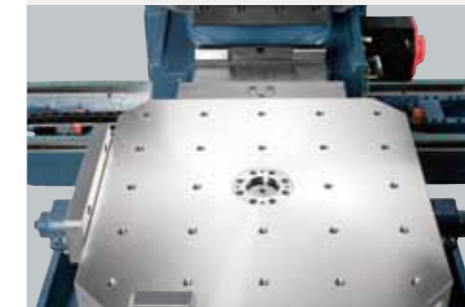

LV series
Horizontal Production Center

- Standard with ISO40 spindle, 8000 rpm gear drive.
- Rear chip disposal design.
- High speed rapid feedrate of 30 / 24 / 30.
- Machine pallet can be T-slotted or bolt-holed.
- Available with Auto Pallet Changer (Opt.)
- APC is standard with 1° index or continuous 0.001° (Opt.)

CNC TURNING CENTER

L series



L series
2 to 4 Axes Turning Center

- Available with Gang type turret or 8-position turret (PK-L105A, Opt.)
- Available with 10-position turret or VDI live tooling turret (PK-L210 Series)
- Y axis (PK-L210CMY) allows versatile milling application.
- 45° slant bed design features optimum force flow performance (PK-L210 Series)
- 0.001° C axis index (PK-L210 Series)

MANUAL MILLING MACHINE

PK series



PK series
Easy and Convenient Manual Miller

- Available with R8, NT30 or NT40 spindle.
- Dove tail slideways with hand-scraped Turcite B.
- Slideways are hardened and fine ground.
- Turret type machine head is driven by inverter motor, variable speed changer, or step speed changer.
- Turret type machine head can be swiveled ±45°.
- Bed type milling machine (PK-B3K) is suitable for heavy load work pieces.

AXseries

Flexible application on robust structure
simple and compact design
 to solve your most complicated machining jobs.

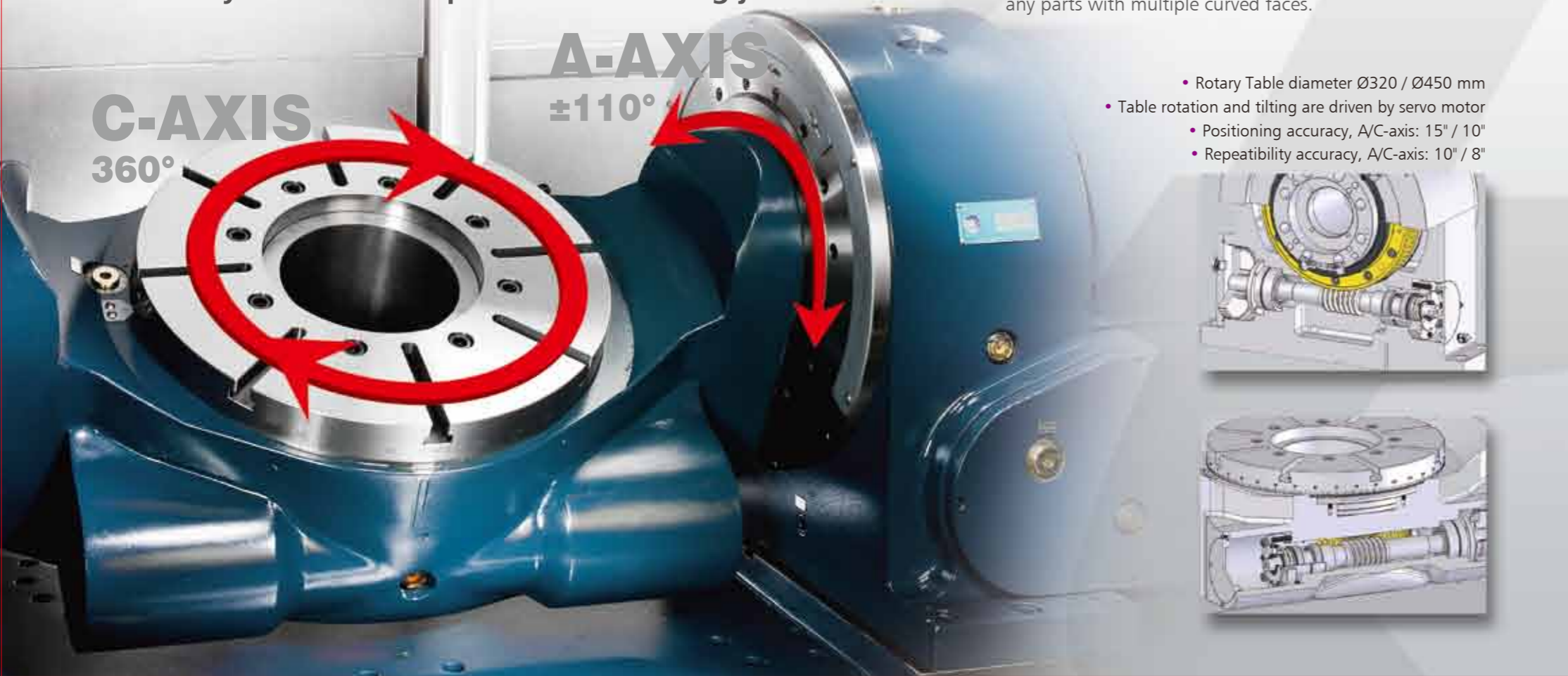

5-AXIS MACHINING CENTER

The main components are made from high quality Meehanite cast iron, which are annealed and stress-relieved before machining. The spindle with entire headstock assembly is counter-balanced by pneumatic system to minimize the column and headstock vibration during acceleration / deceleration.

The 5-axis synchronized machining allows complicated work pieces to be finished in just one setup, and it increases machining efficiency and accuracy, also reduces machine idle time.

Pinnacle AX 320 / AX 450 are your best choices for producing aerospace components, medical equipment and any parts with multiple curved faces.

- Rotary Table diameter Ø320 / Ø450 mm
- Table rotation and tilting are driven by servo motor
- Positioning accuracy, A/C-axis: 15" / 10"
- Repeatability accuracy, A/C-axis: 10" / 8"

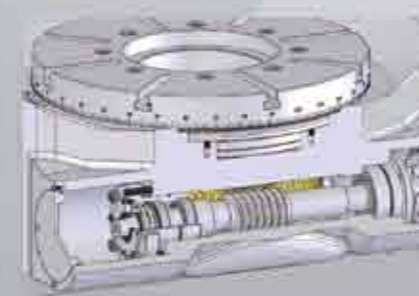
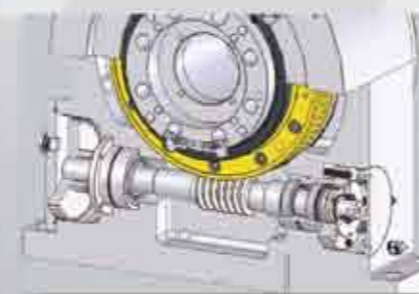

- Rotary Table diameter Ø170 mm
- Table rotation and tilting are DD motor
- Positioning accuracy, A/C-axis: 5"/5"
- Repeatability accuracy, A/C-axis: 8"/4"

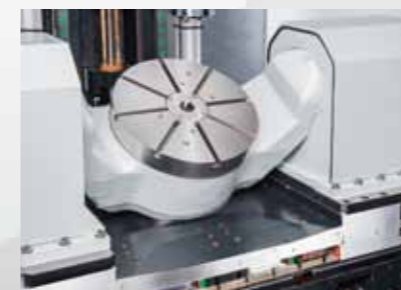

- Rotary Table diameter Ø500 mm
- Table rotation and tilting are DD motor
- Positioning accuracy, A/C-axis: 8"/8"
- Repeatability accuracy, A/C-axis: 4"/4"



■ SPECIFICATIONS:

MODEL	UNIT	AX170	AX320	AX450	AX500
X / Y / Z Travel	mm	320 / 320 / 380	660 / 610 / 610	760 / 610 / 560	760 / 610 / 560
Rotary Table Dia.	mm	170	320	450	500
Tilting A Axis Range	Degree	240° (-120°/+120°)	150° (-120°/+30°)	220° (-110° /+110°)	220° (-110°/+110°)
Rotary C Axis Range	Degree	360°	360°	360°	360°
Spindle Taper		ISO40	ISO40	ISO40	ISO40
Spindle Speed (Opt.)	rpm	15000rpm	10000 (12000)	10000 (12000)	10000 (12000/15000rpm)
Auto Tool Changer (Opt.)	piece	20	24 (30, 40)	24 (30, 40)	24 (30, 40)

● ALL SPECIFICATIONS AND DESIGNS ARE SUBJECT TO CHANGE WITHOUT NOTICE.

BX series

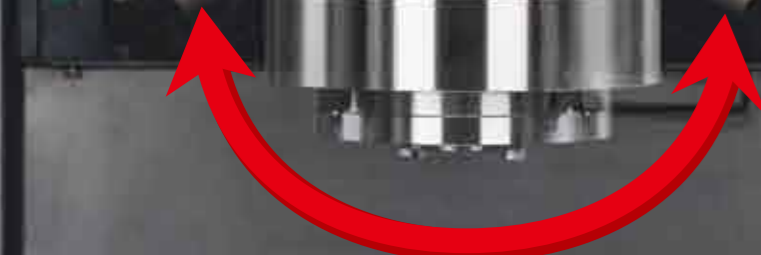

B-AXIS
±120°

Optimum rigidity by separating rotary axis and tiling axis.

5-AXIS MACHINING CENTER

BX series machines by Pinnacle offer the latest and most precise 5-axis technology in the market. Simplify setup and production of complex and multi-sided parts without sacrificing precision and accuracy and saving time. Optimized 5-axis concepts meet every requirement and prevail in all industries worldwide. BX series by Pinnacle are high rigidity structures to provide the widest working range. High quality Meehanite casting iron, tempered for stress relief and over HB190 hardness to ensure deformation-free performance year after year.

Unique Patented Design

Patent No. M386957 (Taiwan)
ZL200920219035.9 (China)

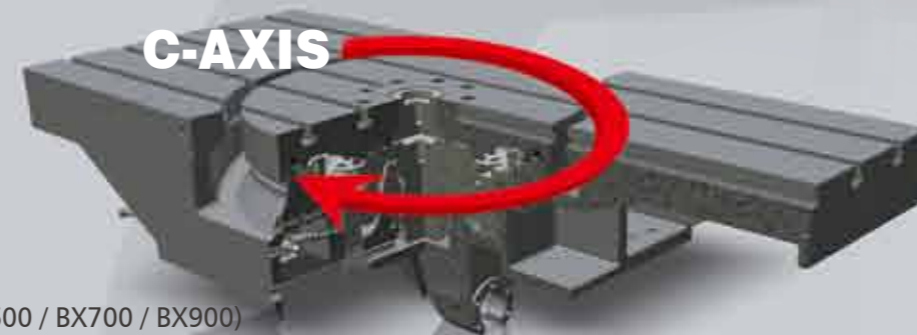

Built-in C-axis (BX500 / BX700 / BX900)

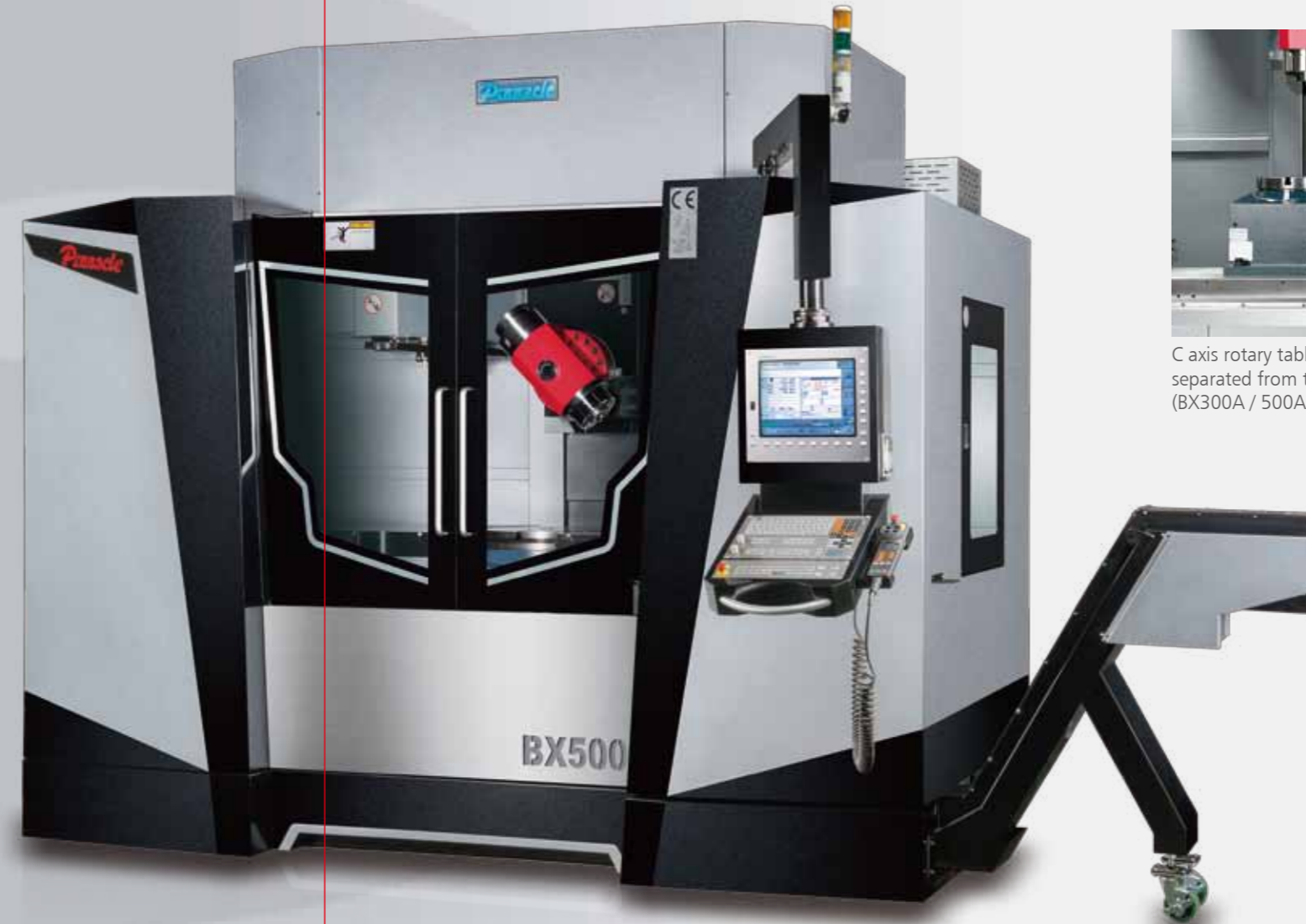

C axis rotary table can be separated from the machine. (BX300A / 500A / 700A / 900A)



Mill & Turn

Pinnacle BX is the best cost-effective manufacturing investment of 5-axis simultaneously controlled machining centers, it brings positive and instant results by improving machining accuracy and reducing cutting time.



BX500 / BX700 / BX900 is high speed, high accuracy with HEIDENHAIN TNC640 5-axis simultaneously controlled machining center. Equips 15000rpm built-in spindle, B-axis swivel head ±120°, and C-axis Ø500 / Ø630 / Ø800mm rotary table (Built-in DD C-axis) to optimize machining space and allows complex workpieces to be finished in just one setup and reduces cycle time.

Integrated C axis with T-Slot Table (BX500 / BX700 / BX900):

1. Rotary table surface and standard T-slot table are on the same plane, it accommodates larger and heavier work pieces.
2. Direct drive C axis (Built-in C axis).
3. 0.001° minimum position accuracy supported by high rigidity bearing and hydraulic braking system.
4. Permanent magnetic motor provides high torque output and high power to meet different cutting application demands.
5. Turning function as option (BX700T / BX900T)

■ SPECIFICATIONS:

MODEL	UNIT	BX300A	BX500A	BX700A	BX900A	BX500	BX700	BX900
XY/Z Travel	mm	1140 / 610 / 810	1300 / 610 / 810	1400 / 710 / 810	1500 / 900 / 1150	1300 / 610 / 810	1400 / 710 / 810	1500 / 900 / 1150
Rotary Table Dia.	mm	320	500	630	630	500	630	800
Swiveling B Axis Range	Degree	240°(+120° / -120°)						
Rotary C Axis Range	Degree	360°						
Spindle Taper		ISO40						
Spindle Speed	rpm	15000						
Auto Tool Changer (Opt.)	piece	30 (40, 60)	30 (40, 60)	40 (60)	40 (60)	30 (40, 60)	40 (60)	40 (60)

● ALL SPECIFICATIONS AND DESIGNS ARE SUBJECT TO CHANGE WITHOUT NOTICE.

DV series

Two linear guideways on the cross beam are arranged in a perpendicular direction, featuring the optimum rigidity for sustaining cutting forces from Z and X directions. The structure also allows the motion control on Y axis to the best condition.

Robust structure

- All major structural parts are manufactured from high quality cast iron with tempering to relieve stress, ensuring maximum material stability without deformation.
- Box type structural parts are rib reinforced to increase structural strength and rigidity.
- Extra heavy base completely supports the table and resists heavy loads without deformation.

DV-14

The columns and cross beam are made from one piece Meehanite cast iron, offering outstanding support to handle heavy duty cutting.

Extra large contact surface between column and machine base.



DOUBLE COLUMN MACHINING CENTER

FEATURES:

- Available with Automatic Head Changer and head storage cabinet. The machine is capable of working with 90° head, universal head or extension head (Opt.)
- The cutting tool change can be automatically changed in vertical or horizontal direction.
- Applicable with Fork Type (B, C axis) head for 5 face machining.
- The milling head can be change manually as well.



90° degree head



ATC unit

SPECIFICATIONS:

MODEL	UNIT	DV-14	DV-17	DV-19	DV-21
X Travel	mm	1700 / 2200 / 3200 / 4200	2200 / 3200 / 4200	2200 / 3200 / 4200	2200 / 3200 / 4200
Y Travel	mm	1400	1700	1900	2100
Z Travel	mm	900 (1100)			
Spindle Taper		ISO40		ISO50	
Spindle Speed	rpm	10000 (12000)			8000
Auto Tool Changer (Opt.)	piece	40 (24 / 60)			32 (24 / 60)

● ALL SPECIFICATIONS AND DESIGNS ARE SUBJECT TO CHANGE WITHOUT NOTICE.

Full Splash Guard (Opt.)



QV series



Four Slideways on Y Axis **fully support** the x axis from **overhanging problem.**

Compact design with minimum footprint size accommodates large and heavy work pieces

- The major structural parts are manufactured from high quality Meehanite cast iron (FC-30), which is stress relieved and aged.
- All axes are equipped with C3 class pretensioned ball screws.
- The counter-balance block moves on a guiding shaft for added stability and better cutting finishes.

4-slideway



Belt-driven ISO40 spindle.



Gear-driven ISO50 spindle.

BOX way series

- Box slideways are hardened by high frequency induction with depth of minimum 2 mm. The hardness is over HRC 55.
- The contact sliding surfaces are coated and finely scraped.

SPECIFICATIONS:

MODEL	UNIT	QV117	QV137	QV147	QV159	QV179	QV209
XYZ Travel	mm	1140 / 710 / 610	1300 / 710 / 610	1400 / 710 / 610	1500 / 900 / 850	1700 / 900 / 850	2000 / 900 / 850
Spindle Taper		ISO40		ISO50	ISO40		ISO50
Spindle Speed / Belt drive	rpm	8000 (opt. 10000)		6000 (opt. 8000)	8000 (opt. 10000)		6000 (opt. 8000)
Spindle Speed / Direct drive	rpm	12000		N/A	12000		N/A
Spindle Speed / Gear drive	rpm	8000		6000	8000		6000
Auto Tool Changer (Opt.)	Piece	24		24 (32)	24		24 (32)

• ALL SPECIFICATIONS AND DESIGNS ARE SUBJECT TO CHANGE WITHOUT NOTICE.

SV series



Extra Wide Machine Base
1100 mm

SV is designed for **extra value** and **built** for optimum performance

The ergonomical structural design

Pinnacle machines are all ergonomically designed to increase the comfort level of the operator, and to reduce the operator's physical fatigue during long time operation. The distance between table and operator is reduced to the minimum, featuring easy loading and unloading of work pieces.



The hardened box guideways are heat treated with high frequency induction, the hardened depth is more than 2 mm., the surface hardness is higher than HRC 55.

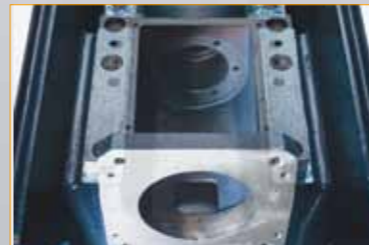

The sliding contact surfaces, flange of motor seats or ball screw seats are fine scraped by hand, the standard is at least 12-scrapes per square inch.



SV105

Heavy duty

Now you can get the right VMC with the right features for extra heavy-duty machining, superior stability and excellent rigidity. Pinnacle's box way SV series are quality constructed throughout for maximum performance dependability - year after year. If you expect a VMC that will provide higher machining efficiency to reduce production costs, then consider placing a dependable, heavy-duty Pinnacle SV series in your production line.

SV116 and SV-126 are available with ISO50 spindle (Opt.).



SPECIFICATIONS:

MODEL	UNIT	SV85	SV105	SV116	SV126
XYZ Travel	mm	850 / 560 / 560	1020 / 560 / 560	1140 / 610 / 610	1300 / 610 / 610
Spindle Taper		ISO40		ISO40	ISO50
Spindle Speed / Belt drive	rpm	8000 (10000)		8000 (10000)	6000 / 8000
Spindle Speed / Direct drive	rpm	12000		12000	N/A
Gear drive	rpm	8000		8000	N/A
Auto Tool Changer (Opt.)	Piece	20 (24)		20 (24)	24

● ALL SPECIFICATIONS AND DESIGNS ARE SUBJECT TO CHANGE WITHOUT NOTICE.

LV

series

Less Friction, More Speed, More Efficiency!



Roller Linear Guideways provide higher cutting efficiency as well as accuracy.

When jobs call for highly efficient machining and when outstanding accuracy is critical, a Pinnacle linear guideway machine is the perfect solution. The three axes move on roller linear guideways that minimize friction, while providing high accuracy of positioning and repeatability.

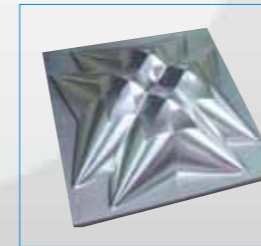

The LV series has wide range application fields for mass production. It is ideal for small job shops as well. From aluminum, copper or all kinds of alloy, LV is the best choice.

Direct-driven ISO40 spindle.

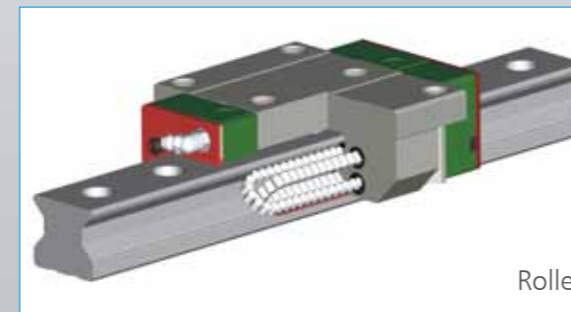

Roller

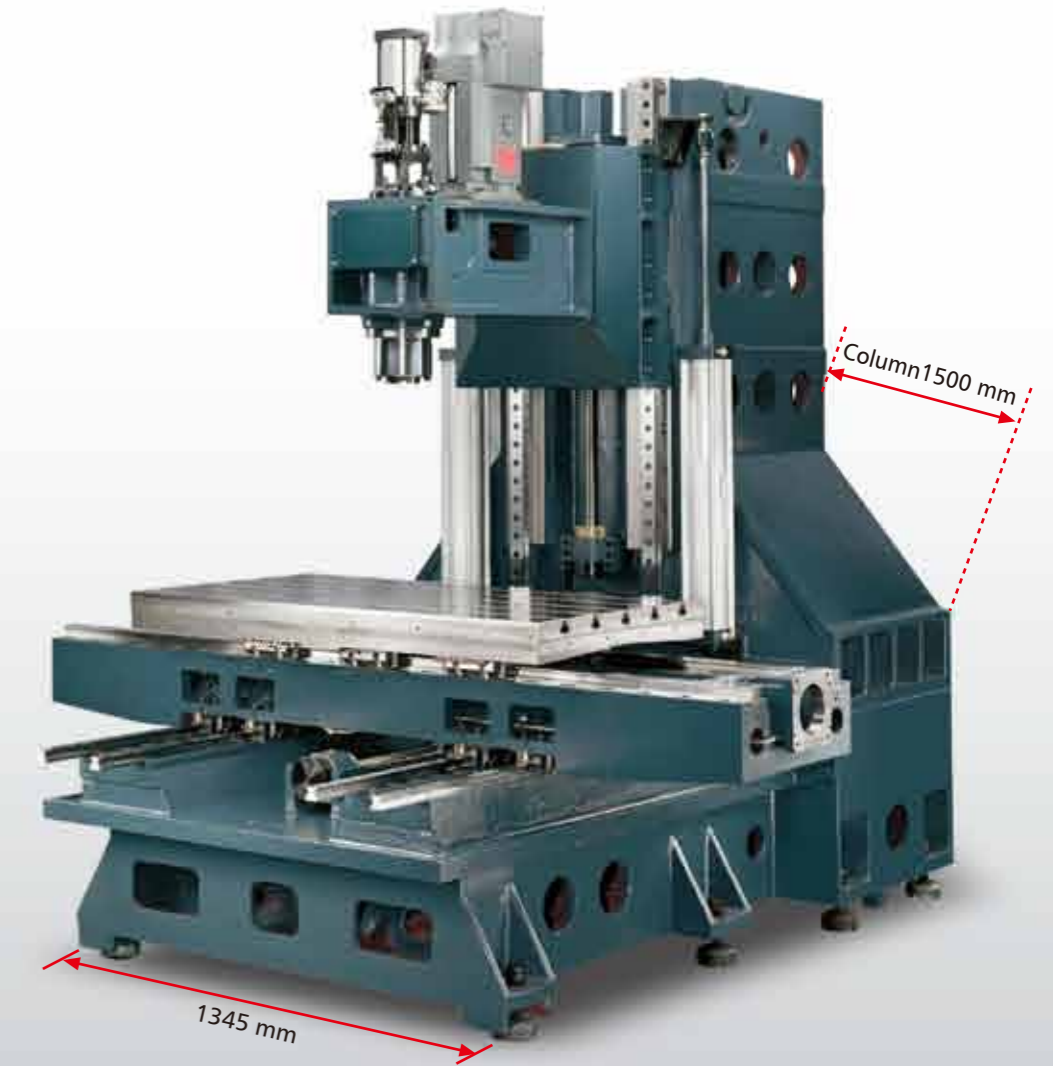

SPECIFICATIONS:

MODEL	UNIT	LV85	LV105	LV116	LV126	LV117	LV137	LV147	LV159	LV170	LV209
XYZ Travel	mm	850 / 560 / 560	1020 / 560 / 560	1140 / 610 / 610	1300 / 610 / 610	1140 / 710 / 610	1300 / 710 / 610	1400 / 710 / 610	1500 / 900 / 850	1700 / 900 / 850	2000 / 900 / 850
Spindle Taper		ISO40		ISO40	ISO50	ISO40	ISO50	ISO50	ISO40		ISO50
Spindle Speed / Belt drive	rpm	8000 (10000)		8000 (10000)	8000	8000 (10000)	6000 (8000)	8000 (10000)	8000 (10000)	6000 (8000)	6000 (8000)
Spindle Speed / Direct drive	rpm	12000 (15000)		12000 (15000)	N/A	12000 (15000)	N/A	12000 (15000)	12000 (15000)	N/A	N/A
Spindle Speed / Gear drive	rpm	8000		8000	N/A	8000	6000	8000	8000	6000	6000
Auto Tool Changer (Opt.)	Piece	20 (24)		20 (24)	16 (24)	24 (30)	24 (32)	24 (30)	24 (30)		24 (32)

● ALL SPECIFICATIONS AND DESIGNS ARE SUBJECT TO CHANGE WITHOUT NOTICE.

LV series

Mold making expert



SPECIFICATIONS:

MODEL	UNIT	LV500B	LV500D	LV500
XYZ Travel	mm	550 / 400 / 400	550 / 400 / 400	550 / 400 / 400
Spindle Taper		ISO30	ISO30	ISO40
Spindle Speed / Direct drive	rpm	N/A	10000 / 12000	10000 / 12000
Spindle Speed / Built-in	rpm	24000	N/A	N/A
Auto Tool Changer (Opt.)	Piece	20	20	20

● ALL SPECIFICATIONS AND DESIGNS ARE SUBJECT TO CHANGE WITHOUT NOTICE.

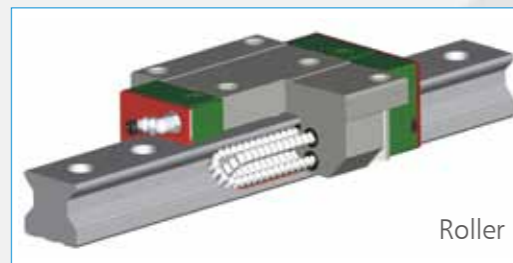

Built-in or direct drive spindle

High speed cutting on hard material, requires ultra high and stable spindle performance. The Pinnacle LV series machine offers either a built-in or direct drive spindle to meet your demands.

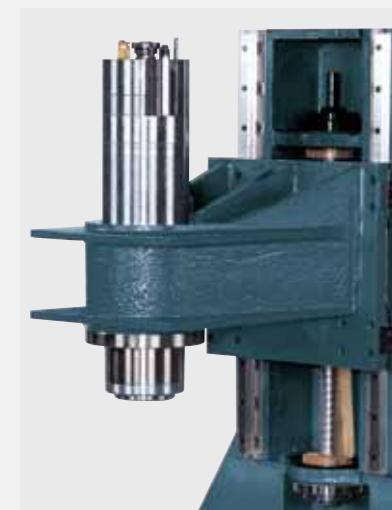

LV-APC series

Rapid and reliable

The machine's compact design features the maximum working space but only requires small footprint size.

Table size: 850 x 500
1000 x 500

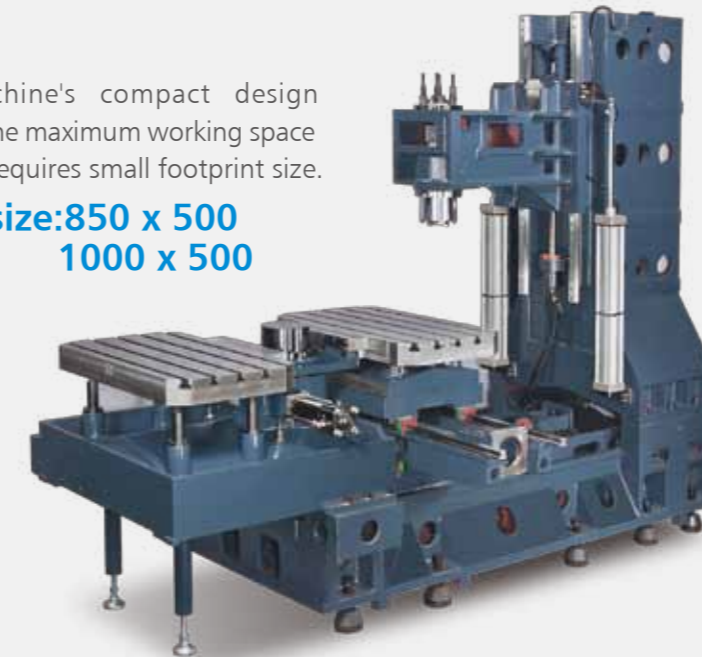

The rotary type auto pallet changer offers non-stop production efficiency. The hydraulic driven mechanism takes only 9 seconds to complete a pallet changing cycle.



The oil through ball screw function minimizes thermo deformation, increases accuracy and stability.



SPECIFICATIONS:

MODEL	UNIT	LV85APC	LV100APC
XYZ Travel	mm	850 / 560 / 560	1020 / 560 / 560
Spindle Taper		ISO40	
Spindle Speed / Belt drive	rpm	8000 (10000)	
Spindle Speed / Direct drive	rpm	12000 / 15000	
Auto Tool Changer	Piece	24	

● ALL SPECIFICATIONS AND DESIGNS ARE SUBJECT TO CHANGE WITHOUT NOTICE.

LH series

A dependable source for
outstanding machinery
to compliment your **workforce**



HORIZONTAL MACHINING CENTER

OPTIMAL STRUCTURE DESIGN

- Fixed Column structure.
- 40-tools Chain type ATC is standard.
- The most compact sized horizontal machining center compared to same models of other manufacturers.



The Automatic Tool Changer unit is seated on column base, the unique design prevents the mass of ATC from bending the machine column.

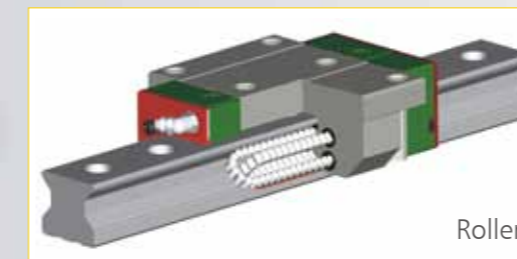

Roller



APC Time: 8 Seconds

■ SPECIFICATIONS:

MODEL	UNIT	LH500A	LH500B
XYZ Travel	mm	650 / 560 / 560	650 / 560 / 560
Spindle Taper		ISO40	ISO40
Pallet Size	mm	500 x 500 x 1 piece	500 x 500 x 2 pieces
Spindle Speed / Gear drive	rpm	8000	8000
Spindle Speed / Belt drive	rpm	8000 / 10000	8000 / 10000
Auto Tool Changer	Piece	40	40

● ALL SPECIFICATIONS AND DESIGNS ARE SUBJECT TO CHANGE WITHOUT NOTICE.

L series

An Uncompromising Approach to more productive parts turning

CNC Turning Center

The Pinnacle Flat Bed CNC Turning Center is designed and built with one thought in mind that customers have come to expect. It delivers high productivity, accuracy and exceptional surface finish. The CNC turning center features up to 6,000 rpm variable spindle speed and a high stock removal rate. A combination of turret and gang type tool slide provides the most versatile turning applications. It is a perfect lathe that assures greater productivity, lower parts costs and really cuts machining downtime for more profitable production.



HEAVY DUTY RIGID DESIGN AND CONSTRUCTION

Rigid Meehanite cast iron construction provides consistent, deformation-free precision machining.

EXCELLENT FEATURES:

- Outstanding reliability for precision parts machining.
- Extra-wide and solid slideways assure maximum rigidity.
- Flexible combinations are ideal for production suitable for a wide variety of applications, such as: 3C parts, medical equipment components, automotive parts and optical materials.
- Powerful spindle motor and a capacity of 65/77 mm for bars that greatly increases machining options.
- Extra efficient chip collection and water drainage is achieved with the 45° slant design.

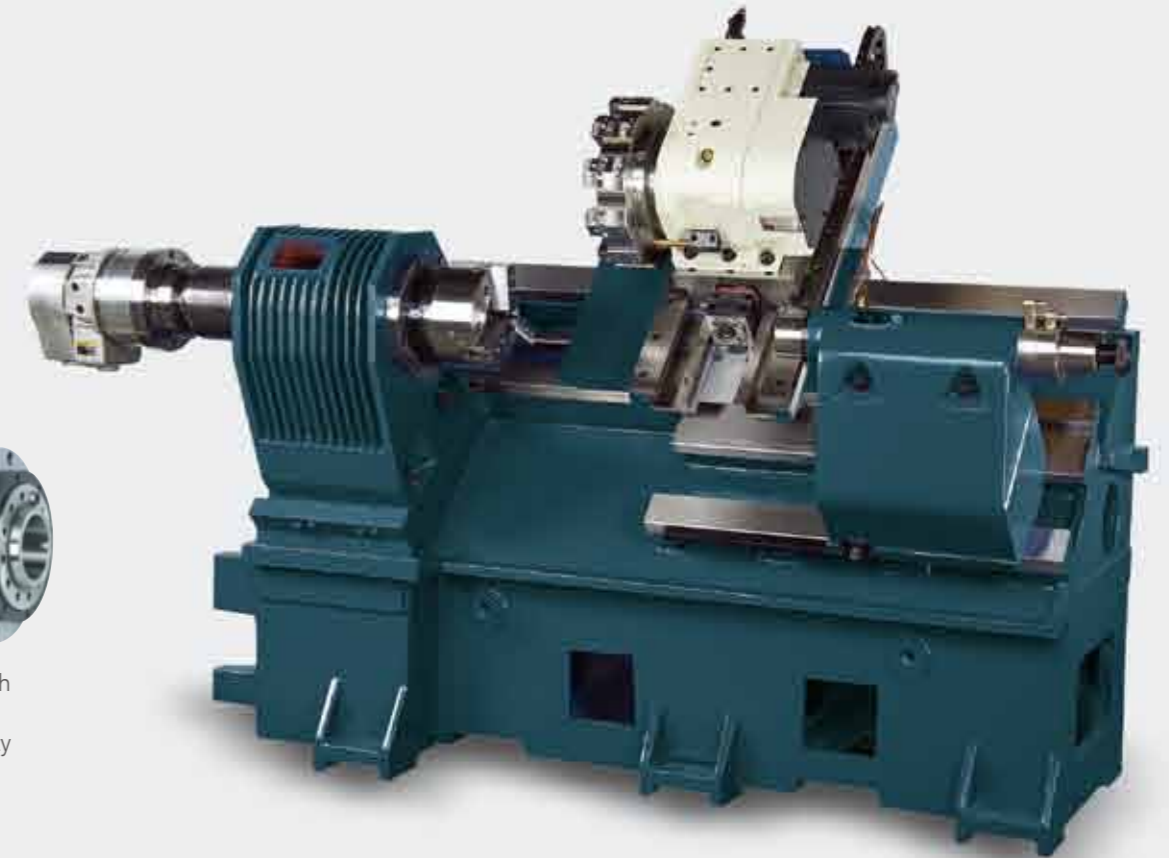

MITSUBISHI SJ-15A

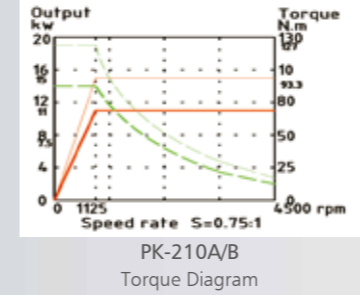

RIGID SPINDLE

- Supported by superior precision high speed angular ball bearings to provide extra wide range machining capacity and increase rigidity, as well as extend spindle bearing life.

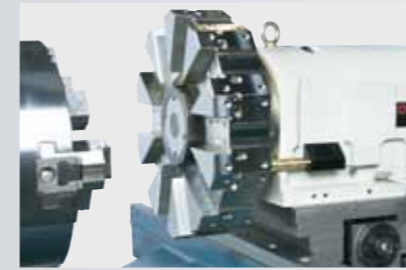

10-POSITION SERVO TURRET

- The rigid turret features outstanding stability while turning.
- The turret can be mounted with 25 x 25 mm. O.D. tools and 40 mm. boring tools.



HYDRAULIC CHUCK

- The hydraulic chuck is controlled by a foot switch for efficient and convenient operations.

SPECIFICATIONS:

MODEL	UNIT	L150A	L210A	L210B	L210C	L210D	L210A/BMY	L210C/DMY
Swing Over Bed	mm	330	520	520	520	520	750	750
Max. Turning Length	mm	150	610	610	610	610	570	570
Spindle / Chuck Size	Inch	A2-5 / 6"	A2-6 / 8"	A2-6 / 10"	A2-8 / 10"	A2-8 / 12"	A2-6 / 8"or10"	A2-8 / 10"or12"
X/Z Travel	mm	150 / 280	210 / 610	210 / 610	210 / 610	210 / 610	195 / 570 / 80 (±40)	195 / 570 / 80 (±40)
Spindle Speed	rpm	6000	4500	4500	3500	3500	3500	4500
Turret Capacity	pcs	8 (Gang Type)	10 (12)	10 (12)	10 (12)	10 (12)	12	12

• ALL SPECIFICATIONS AND DESIGNS ARE SUBJECT TO CHANGE WITHOUT NOTICE.

PK-B3K CNC

- BT40 spindle
- Maximum 8000 rpm
- 5.5 kW spindle motor
- Carousel type ATC with 16 tools capacity
- Bed type structure
- Optional full guarding



PK-B3K

- 3 axes are driven by inverter motors
- High rigidity NT#40 spindle
- 5 HP high power spindle motor
- Fine-ground T-slots
- Bed type structure suitable for heavy work pieces
- Slideways are hardened



PK-FV3

- The spindle is driven by high power 5HP inverter motor
- Large table NT#40 spindle surface.
- X and Y axes are driven by inverter motors
- Oversized box guideways on machine column ensures rigid and stable Z axis movement

PK-GRSM-V

- 3HP variable speed head
- NT30# / R8 spindle taper
- 3HP powerful motor
- Square slideways on knee.
- Extra wide table working area 50" x 10"
- Hardened and ground X,Y axes and table surface



1 1/2GRM-KB

- 16-speed range milling head
- NT30# / R8 spindle taper
- Step pulley head with 2HP motor
- Dovetail slideways
- Hardened and ground X,Y axes and table surface



PK series

SPECIFICATIONS:

MODEL	UNIT	PK-B3K CNC	PK-B3K	PK-FV3	PK-FV2
X/Y/Z Travel	mm	1020 / 460 / 500	1020 / 510 / 510	800 / 400 / 380	900 / 380 / 380
Table Size	mm	1524 x 305	1524 x 305 (Bed Type)	1524 x 305	1372 x 254
Spindle Taper		BT#40	NT#40	NT#40	NT#40
Spindle Motor	HP	5.5	5 / Inverter	5 / Inverter	5 / Inverter
Spindle Speed	rpm	8000	Inverter Variable 4200	Inverter Variable 4200	Inverter Variable 4200

SPECIFICATIONS:

MODEL	UNIT	PK-GRSM-V2	PK-GRSM-B2	PK-GRSM-V
X/Y/Z Travel	mm	900 / 380 / 380	900 / 380 / 380	800 / 380 / 380
Table Size	mm	1372 x 254	1372 x 254	1270 x 254
Spindle Taper		NT#40	NT#40	R8 or NT#30
Spindle Motor	HP	5 / Induction	5 / Induction	3 (5) / Induction
Spindle Speed	rpm	Stepless 3800	16-Step 3820	Stepless 3800

SPECIFICATIONS:

MODEL	UNIT	PK-GRSM-B	PK-1 1/2GRM-KV	PK-1 1/2GRM-KB
X/Y/Z Travel	mm	800 / 380 / 380	680 / 355 / 406	680 / 355 / 406
Table Size	mm	1270 x 254	1067 x 230 or 1245 x 230	1067 x 230 or 1245 x 230
Spindle Taper		R8 or NT#30	R8 or NT#30	R8 or NT#30
Spindle Motor	HP	3 (5) / Induction	2 (3) / Induction	2 (3) / Induction
Spindle Speed	rpm	16-Step 3820	Stepless 3800	16-Step 3820

● ALL SPECIFICATIONS AND DESIGNS ARE SUBJECT TO CHANGE WITHOUT NOTICE.